

DENON

PROFESSIONAL



DN-104S

4-INCH COMMERCIAL-GRADE CEILING LOUDSPEAKER

Denon Professional's range of ceiling loudspeakers is designed to deliver exceptionally accurate, articulate sound while easily meeting commercial requirements for fire-resistance (EN 54-24) and suitability for multiple unit installation.

All three models feature a metal "can" rear enclosure, which provides a fire barrier behind the speaker to meet commercial fire codes. It also serves as the woofer's enclosure to optimize its bass tuning and low frequency response. The speakers have 70/100-volt transformers to facilitate multiple unit installations without the impedance and level-matching concerns of paralleled transformerless speakers.

There are three different size models with 4-inch, 6 1/2-inch and 8-inch woofers. All three utilize high quality drive units in tuned reflex enclosures and precision electronic crossovers to deliver clean, detailed sound, perfect for music, public address applications and business/educational presentations, while meeting all safety and fire codes as required by commercial venues.

FEATURES

- 4-inch long-excursion woofers
- 20mm wide dispersion dome tweeter
- Driver Power: 30 W (RMS) 60 W (Peak)
- 70/100V transformers for multi-unit installations
- Metal rear enclosures meet commercial fire codes
- Frequency response: 80-20kHz
- Mounting Bracket Included
- EN 54-24 Compliant

SPECIFICATIONS

SYSTEM PERFORMANCE

Frequency Range (-10dB):	100 Hz—20 kHz
Power Capacity:	60 W Peak
Nominal Sensitivity:	86dB SPL, 1W @ 1m (3.3 ft)
Nominal Dispersion:	120° Conical coverage pattern
Directivity Factor (Q):	6.7 Averaged from 100 Hz to 4 kHz
Directivity Index (DI):	7.1 Averaged from 100 Hz to 4 kHz
Rated Maximum SPL:	102dB
Nominal Impedance:	16 Ω
Transformer Taps:	Direct: 16 Ω 70V: 10W, 5W, 2.5W, 1.25W 100V: 10W, 5W, 2.5W

TRANSDUCERS

Low Frequency:	4" Poly Propylene-coated, 0.75" Aluminum VC Driver
High Frequency:	20mm (¾") PEI Dome Tweeter

PHYSICAL

Enclosure:	Metal Enclosure with ABS baffle and magnetic grille
Termination:	4 position Euro Style Connector with 5mm spacing
Safety Agency Ratings:	EN54-24, UL 2043 pending
Outside Dimensions:	8.85" (218 mm) diam x 4.92" (125 mm) H
Cutout Size:	7.25" (184.1 mm) diam
Net Weight:	4.7 lbs (2.15 kg)
Shipping Weight:	7 lbs (3.18 kg)
Included Accessories:	Euro Style Mating connector, Magnetic Grille, Ceiling Tile Brackets and Bracket Screws

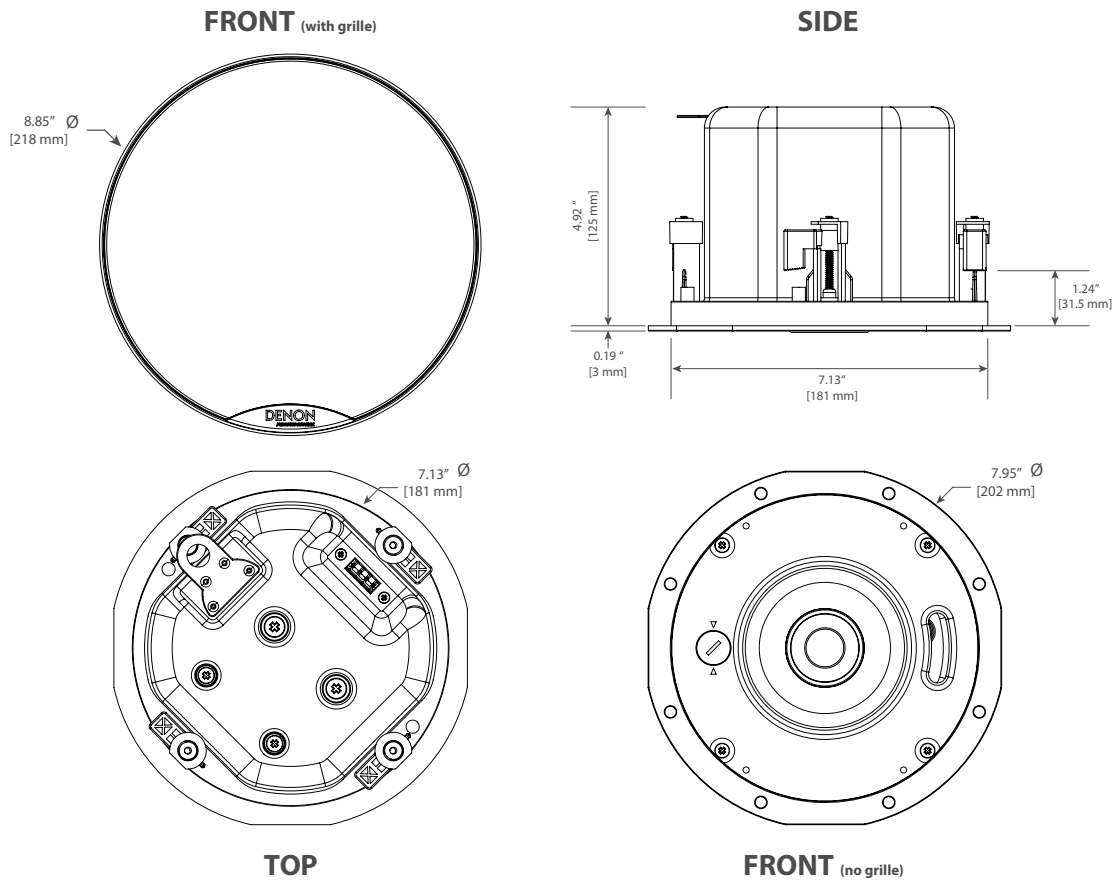

ON-AXIS FREQUENCY RESPONSE



DIRECTIVITY

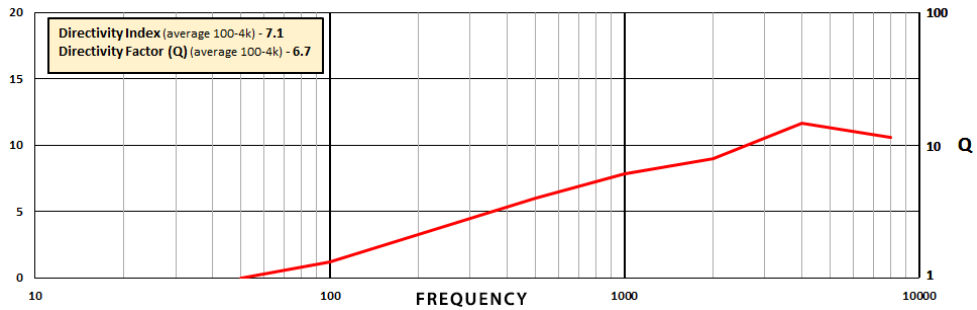

IMPEDANCE AND PHASE

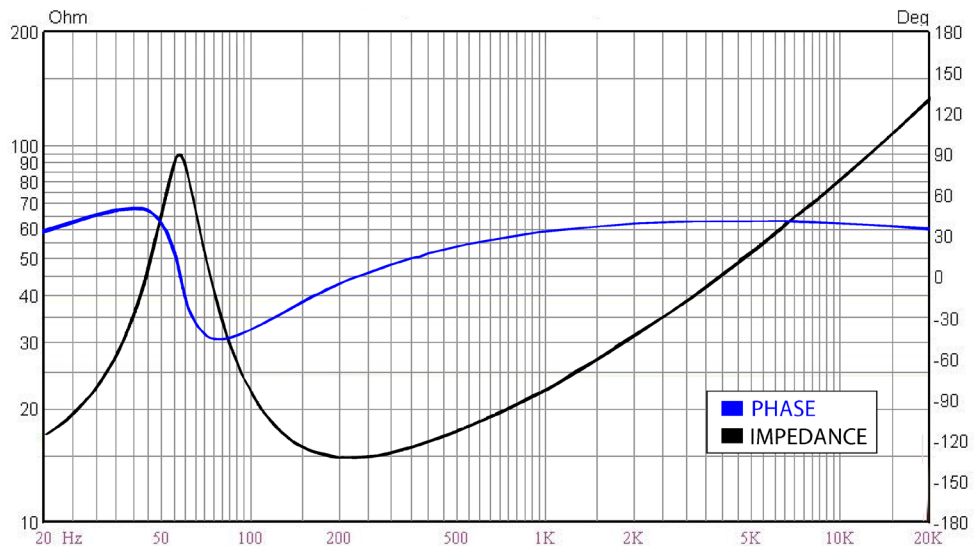

POLAR PLOTS

