

DENON DJ

SC6000
PRIME

SC6000M
PRIME

SC5000
PRIME

SC5000M
PRIME

User Guide

English

Table of Contents

Introduction	4	Features	11
Box Contents.....	4	SC6000 PRIME	11
Support	5	Top Panel.....	11
Product Registration.....	5	Media Selection & Browsing.....	11
Setup	6	Playback & Transport Controls..	12
1. Assemble the Platter System		Sync & Pitch Controls	12
(SC6000M/SC500M PRIME		Performance Controls.....	13
only)	6	Front Panel.....	14
SC6000M PRIME.....	6	Rear Panel.....	14
SC5000M PRIME.....	6	SC6000M PRIME	15
2. Connect and Start DJing!.....	7	Top Panel.....	15
Connection Diagrams.....	7	Media Selection & Browsing.....	15
Devices & File Analysis.....	9	Playback & Transport Controls..	16
Networking	9	Sync & Pitch Controls	16
Configuration.....	10	Performance Controls.....	17
		Front Panel.....	18
		Rear Panel.....	18
		SC5000 PRIME	19
		Top Panel.....	19
		Media Selection & Browsing.....	19
		Playback & Transport Controls..	20
		Sync & Pitch Controls	20
		Performance Controls.....	21
		Front Panel.....	22
		Rear Panel.....	22

SC5000M PRIME	23	Pad Modes.....	43
Top Panel.....	23	Hot Cue Mode	43
Media Selection & Browsing	23	Loop Modes	43
Playback & Transport Controls .	24	Roll Mode	44
Sync & Pitch Controls.....	24	Slicer Mode	44
Performance Controls.....	25	Sampler Mode.....	45
Front Panel	26	Stems Mode.....	46
Rear Panel	26	Touch FX.....	47
 		Control Center	48
Operation.....	27	Parameters.....	48
 		Layout	49
 Touchscreen Overview.....	27	Profile.....	51
Performance View.....	27	Settings.....	54
Track Overview & Waveform.....	27	Source.....	56
Performance Library	29	Engine Remote Library.....	56
Toolbar.....	30	Wi-Fi.....	57
Library View	31	Bluetooth®	58
 		Engine Lighting	59
 Platter Display Overview		Preferences	60
 (SC6000/SC5000 PRIME only) .	33	 	
 		Appendix	61
 Performing	34	 	
Loading & Removing Tracks.....	34	 SATA Drive Installation.....	61
Searching & Filtering Tracks	35	 	
Match.....	36	 Touch FX.....	62
Editing Playlists.....	37	 	
Playback & Cueing.....	38	 Technical Specifications	64
Looping & Beat-Jumping	39	 	
Syncing & Pitch Adjustment	40	 Trademarks & Licenses.....	65
Beat Grid Editing	42		

Introduction

Thank you for purchasing your PRIME hardware. At Denon DJ, we know how serious music is to you. That's why we design our equipment with only one thing in mind—to make your performance the best it can be. We're honored and excited to play a part in your musical and creative DJ journey!

Features:

- 24-bit / 96kHz uncompromised digital audio output
- Built-in Wi-Fi and wired internet connectivity for music streaming
- Dual-layer playback with independent analog & digital outputs
- Plays uncompressed audio formats (FLAC, ALAC, WAV, AIFF)
- On-board analysis of music files & collection management
- Best-in-class time stretch and musical key change/sync algorithms
- Media inputs include: (3) USB, SD, and internal SATA drive bay
- Responsive rubber buttons and multi-function performance pads
- Customizable RGB color around the jog wheel
- LAN output to link players and control pro DJ lighting and video
- Includes Engine DJ music management software

SC6000 PRIME / SC6000M PRIME Features:

- 10.1" HD multi-touch display with gesture support
- **SC6000 PRIME:** 8.5" jog wheel with tension adjust & HD color display
- **SC6000M PRIME:** 8.5" motorized platter with torque adjust & quick release vinyl
- Locking IEC connector for secured power cable

SC5000 PRIME / SC5000M PRIME Features:

- 7" HD display with multi-touch gestures
- **SC5000:** 8" rugged metal jog wheel with HD jog display
- **SC5000M:** Motorized platter with real 7" vinyl

Box Contents

(2) RCA Audio Cables (stereo pairs)

USB Cable

USB Extension Cable

Networking Cable

Power Cable

Cleaning Cloth

Software Download Card

User Guide

Safety & Warranty Manual

Platter Assembly (SC6000M PRIME / SC5000M PRIME only):

- Aluminum Platter
- Slipmat
- Control Disc with Quick Release Adapter (attached)
- Allen wrench (SC5000M only)

Support

For the latest information about this product (documentation, technical specifications, system requirements, compatibility information, etc.), visit denondj.com.

For additional product support, visit denondj.com/support.

Product Registration

Your product may include exclusive software and/or promotions which can only be accessed by registering your new product on the Denon DJ website.

To check eligibility and access the available content, please register your product by following the instructions below:

1. Visit denondj.com and click **Account**.
2. Click **Sign In** to access your existing account, or create a new account.
3. Once signed in, click **Register New Product**.
4. Enter the product serial number into the box and click **Check Serial**.
5. Complete the form and click **Register Your Product**.
6. Upon successful registration, any applicable software downloads, exclusive content, and promotional offers will be shown in your account.

Setup

1. Assemble the Platter System (SC6000M/SC5000M PRIME only)

SC6000M PRIME

1. Remove the SC6000M PRIME base from the packaging. Remove the platter assembly from the package. Place SC6000M PRIME on a flat, stable surface for assembly and operation.
2. Place the platter onto the SC6000M PRIME base by aligning the pins in the bottom of the platter with the holes in SC6000M PRIME's motor. Press it down firmly. Check to make sure that it rotates uniformly and does not wobble excessively.
3. Place the slipmat onto the platter. Then place the **Control Disc** over the spindle (with the attached **Quick Release Adapter** on top). To lock the **Control Disc** to the spindle, pinch the top of the spindle while slowly rotating the disc until you hear it click. It locks when the groove in the spindle lines up directly opposite to the button on the side of the **Quick Release Adapter**.

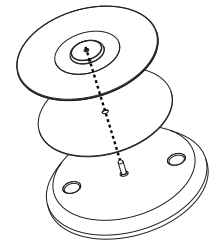
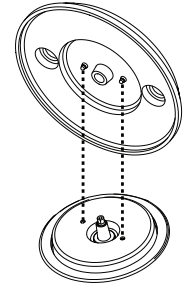

SC5000M PRIME

1. Remove the SC5000M base from the packaging. Remove the platter assembly from the package (underneath SC5000M). Place SC5000M on a flat, stable surface for assembly and operation.
2. Place the platter onto the SC5000M base by aligning the pins in the bottom of the platter with the holes in SC5000M's motor. Press it down firmly. Check to make sure that it rotates uniformly and does not wobble excessively.
3. Place the slipmat onto the platter, then place the vinyl over the slipmat.
4. Line up the notch in the spindle with the screw in the spindle lock adapter. Use the Allen wrench (included) to tighten the screw, locking the adapter to the spindle.

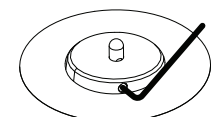
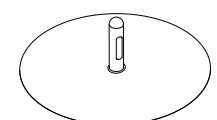
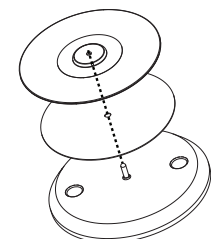
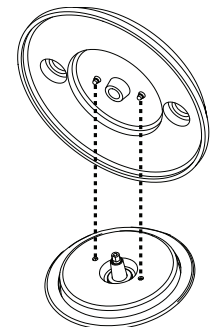

Note: By pressing down on or lifting up the vinyl while you tighten the spindle screw, you can adjust the slip friction to your preferred feel.

2. Connect and Start DJing!

Important: Occasionally, we may update the PRIME hardware's firmware to add exciting new features and improvements. Visit enginedj.com/downloads to check for available firmware updates, especially after you update your software (firmware updates may address new software features).

1. Visit enginedj.com/downloads to download the Engine DJ software to pre-analyze your music library to use with the PRIME hardware.
2. Double-click the **.exe** (Windows®) or **.dmg** (macOS®) installer file you downloaded, and then follow the on-screen instructions to install Engine DJ.
3. Make sure all of your devices are powered **off** or all of their volume levels are at their **minimum** positions.
4. Connect the PRIME hardware's audio outputs (**Layer A/B** or **Digital Outputs A/B**) to the inputs of your mixer.
5. Connect the PRIME hardware's **Link** ports according to one of the following connection diagram examples.
6. Connect any output devices (headphones, power amplifiers, loudspeakers, etc.) to the outputs of your mixer.
7. Connect all of your devices to power sources.
 - When starting a session, power on **(1)** the PRIME hardware and other input sources, **(2)** your mixer, and then **(3)** output devices.
 - When ending a session, power off **(1)** output devices, **(2)** your mixer, and then **(3)** the PRIME hardware and other input sources.
8. **To use Engine OS (standalone playback):** Insert a USB flash drive or SD card (with an Engine-configured music library) to one of the PRIME hardware's **USB ports** or **SD Card Slot**, connect to available streaming and cloud services, or explore the included demo content.

Connection Diagrams

Items shown but not listed under [Box Contents](#) are sold separately.

Example 1

This example shows two PRIME hardware units with their **Link** ports connected to each other directly.

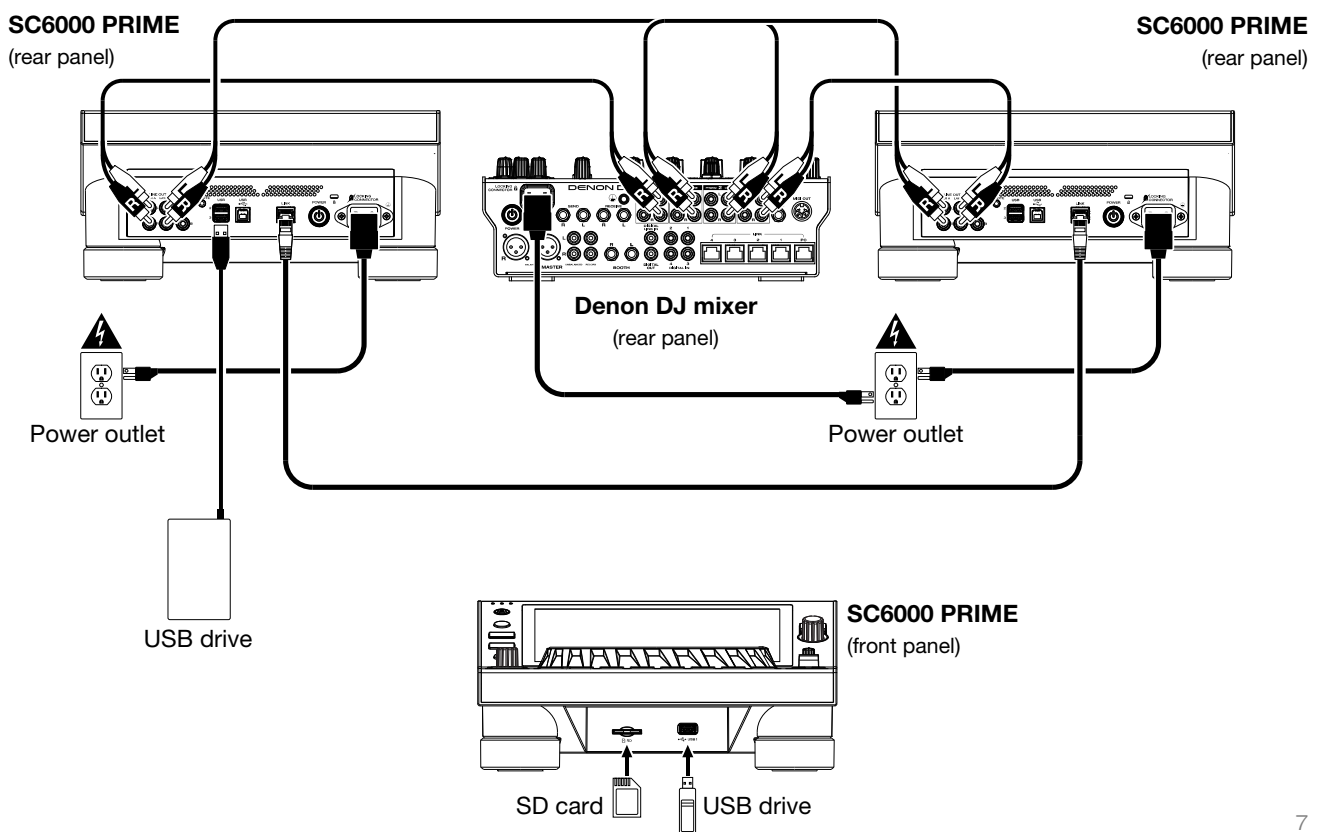

Example 2

This example shows four PRIME hardware units with their **Link** ports connected to **Link Ports 1-4** of a Denon DJ mixer. All four units are networked through the mixer.

Note: If you are using a different mixer with this setup, connect the **Link** ports of all 4 PRIME hardware units to an Ethernet hub instead of to the mixer.

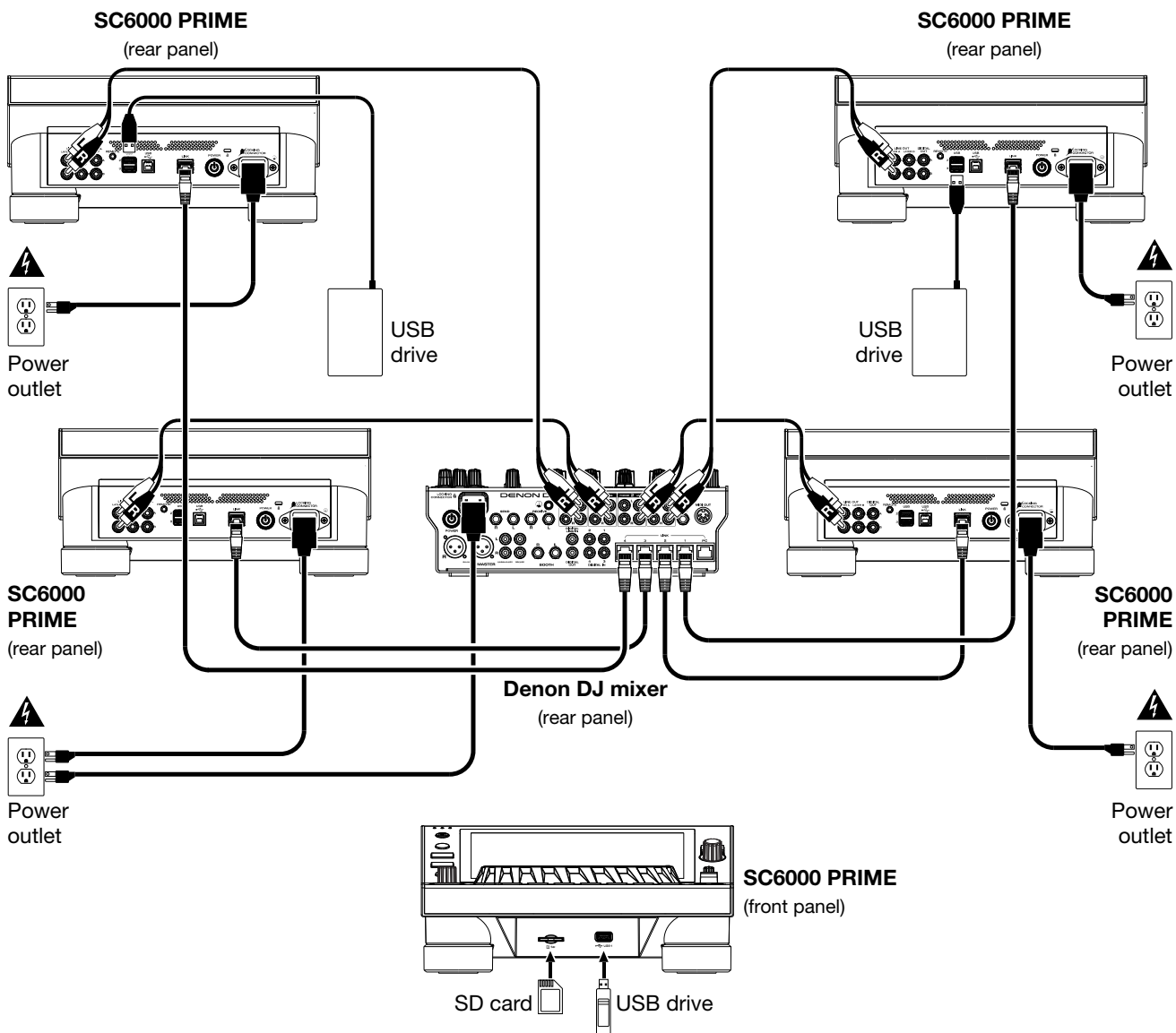

RF Warning: This is a mobile device. Maintain a distance of at least 8 inches / 20 centimeters of separation between the transmitter's radiating structure(s) and your body or other people nearby.

Devices & File Analysis

PRIME hardware can play music files from USB drives, SD cards, or other connected PRIME hardware units. Make sure you are using only the supported file systems (for USB drives or SD cards) and file formats (for music files) listed below.

Supported file systems:	exFAT (recommended), FAT32, HFS+ (SC6000/SC6000M PRIME only)	
Supported file formats:	AAC/M4A	MP3 (32–320 kbps)
	AIF/AIFF (44.1–192 kHz, 16–32-bit)	MP4
	ALAC	Ogg Vorbis
	FLAC	WAV (44.1–192 kHz, 16–32-bit)

Although PRIME hardware can play tracks that have not been analyzed yet, pre-analyzing them allows its features to work most effectively. You can analyze tracks in one of two ways:

- **On the PRIME hardware, load the track:** When you load a track to play, PRIME hardware will automatically analyze it (if it has not already been analyzed). This may take a moment to complete, depending on the length of the track. You can start playing the track from the beginning **immediately**, though you will need to wait a moment for the analysis to finish.
- **Use Engine DJ software:** The included Engine DJ software can pre-analyze your music library to use with the PRIME hardware. You can also use it to organize your library, manage your PRIME hardware preferences, etc. (see [Operation](#) to learn more about this).

Visit enginejdj.com/downloads to download the Engine DJ software.

To eject a USB drive or SD card:

1. Make sure none of its tracks are being played on any connected PRIME hardware units.
2. Press the **Media Eject** button. A list of connected devices will appear in the touchscreen.
3. Tap the **Eject icon** on the touchscreen next to the name of your device. If a track on the device is currently playing, you will be asked if you want to continue ejecting, which will stop the track. Tap **Cancel** to cancel ejecting the device, or tap **OK** to eject it.

To eject additional devices, repeat Step 3.

To return to the previous screen, press the **Media Eject** button again, or tap the **X** in the upper-right corner.

PRIME hardware also supports installation of a **SATA** (Serial ATA) drive to create internal storage space. See [Appendix > SATA Drive Installation](#) for more information.

Networking

You can network up to four PRIME hardware units together, enabling them to share track databases, timing and BPM information, and other data seamlessly over this connection.

This feature provides many advantages while performing. For instance, if you are using four PRIME hardware units, you can use one of them to browse through **all** tracks on **all** devices (USB drives or SD cards) connected to **any** of those the PRIME hardware units. You can then play any of those tracks immediately without having to move a device from one unit to the other.

To network PRIME hardware units together, use the included networking cables to do one of the following:

- If you are using only two PRIME hardware units, connect their two **Link** ports.
- If you are using two or more PRIME hardware units, connect each of their **Link** ports to a **Link** port (1–4) on your Denon DJ mixer.
- If you are using two or more PRIME hardware units, connect each of their **Link** ports to an Ethernet port on a router.

The **Link** light will turn on when the PRIME hardware unit is properly connected to a network.

Configuration

When your PRIME hardware is powered on, you will be presented with a Wi-Fi connection menu to connect to your local network. You can dismiss this screen each time, or set it to not show again at startup. You can adjust your connection settings at any time using the [Wi-Fi](#) menu in the Control Center.

Next, you will be prompted to connect to your Engine DJ profile. With your Engine DJ profile, you can register your device, connect streaming and cloud services so you can log into each with a single Engine DJ profile login, and access crowd-sourced streaming metadata and beat grid information. You can use a mobile device to scan the QR code, or visit device.enginedj.com and enter the code shown. You can also dismiss this screen each time, or set it to not show again at startup. To log in to an Engine DJ profile at any other time, use the **Log In** button found in the [Profile](#) menu.

Your PRIME hardware has more settings that you can customize in the [Layout](#), [Profile](#), and [Settings](#) menus. See [Control Center](#) to learn about these settings.

Playback & Transport Controls

10. **Layer:** Press this button to switch the layer focus of the SC6000 PRIME.
Press and hold **Shift** and press this button to toggle between Single and Dual Layer views.
Note: This button will be disabled if the **Layer B** option under [Layout > Deck Behavior](#) is set to **Off**.
11. **Platter:** This capacitive, touch-sensitive platter controls the audio playhead when the wheel is touched and moved. When the **Vinyl** button is on, move the **platter** to “scratch” the track as you would with a vinyl record. When the **Vinyl** button is off (or if you are touching only the side of the **platter**), move the **platter** to temporarily adjust the track’s speed.
12. **Platter Display:** This display shows information relevant to the performance, including the current playhead position and auto loop size, as well as album artwork. See [Platter Display Overview](#) for more information.
13. **Wheel Adjust:** Turn this knob to set how resistant the platter is to adjustments. This knob applies a brake to the platter to prevent unintentional drifting due to environmental vibrations from bass frequencies, surface instability, etc.
14. **Stop Time:** Controls the rate at which the track slows to a complete stop (“brake time”) when you pause it by pressing **Play/Pause** (▶/||).
15. **Vinyl:** Press this button to activate/deactivate a “vinyl mode” for the platter. When activated, you can use the **platter** to “scratch” the track as you would with a vinyl record.
16. **Play/Pause** (▶/||): This button pauses or resumes playback.
Press and hold **Shift** and then press this button to “stutter-play” the track from the initial cue point.
17. **Cue:** During playback, press this button to return the track to the initial cue point and stop playback.
To move the initial cue point while the track is paused, move the **platter** to place the audio playhead at the desired location, and then press this button. Alternatively, if the track is playing, press and hold **Shift** and then press this button to set the initial cue point at the current playhead position.
If the deck is paused, press and hold this button to temporarily play the track from the initial cue point. Release the button to return the track to the initial cue point and pause it. To continue playback without returning to the initial cue point, press and hold this button and then press and hold the **Play** button, and then release both buttons.
18. **Track Skip:** Press either of these buttons to skip to the previous or next track.
Press the **Previous Track** button in the middle of a paused track to return to the beginning of the track.
Press and hold **Shift** and then press one of these buttons to search backward or forward through the track.

Sync & Pitch Controls

19. **Pitch Fader:** Move this fader to adjust the speed (pitch) of the track. You can adjust its total range by pressing and holding **Shift** and pressing one of the **Pitch Bend** buttons.
Important: If Sync is activated, moving the pitch fader on the “primary” SC6000 PRIME unit will change the speed of all synced units, while moving the pitch fader on other units will do nothing.
20. **Pitch Bend** –/+ : Press and hold one of these buttons to momentarily reduce or increase (respectively) the speed of the track.
Press and hold **Shift** and then press one of these buttons to set the range of the pitch fader.
21. **Key Lock/Reset:** Press this button to activate or deactivate Key Lock. When Key Lock is activated, the track’s key will remain the same even if you adjust its speed.
Press and hold **Shift** and press this button to reset the track to its original key regardless of the position of the **pitch fader** or edits made via key change menu.
22. **Sync/Sync Off:** Press this button to activate Sync.
To sync two or more PRIME units, press **Sync** on the unit that you want to control the BPM, which becomes the “primary.” After Sync is activated on that unit, press **Sync** on any additional units. The units will immediately synchronize according to the Sync Mode setting in the [Profile > Playback](#) menu.
To deactivate Sync, press the **Sync** button again, or press and hold **Shift** and press **Sync**, depending on the **Sync Button Action** setting in the [Profile > Playback](#) menu.
23. **Master:** Press this button to set this SC6000 PRIME unit as the one that controls the lead tempo. All connected units with Sync activated will use this tempo. If you stop the sync lead unit, the next-longest-playing unit in the setup will automatically become the new sync lead (unless you change it manually).

Performance Controls

24. **Shift:** Press and hold this button to access secondary functions of other controls.
25. **Slip:** Press this button to enable or disable Slip Mode. In Slip Mode, you can jump to cue points, use the platter, or pause the track while the track's timeline continues (half of the waveform in the display will continue moving forward). In other words, when you stop whatever action you are performing, the track will resume normal playback from where it would have been if you had never done anything (i.e., as if the track had been playing forward the whole time).
26. **Censor/Reverse:** Press this button to activate the Censor feature: the playback of the track will be reversed, but when you release the button, normal playback will resume from where it would have been if you had never engaged the Censor feature (i.e., as if the track had been playing forward the whole time). Press and hold **Shift** and then press this button to reverse the playback of the track normally. Press this button again to return playback to the normal forward direction.
27. **Performance Pads:** These pads have different functions depending on the current pad mode. See [Pad Modes](#) for more information.
28. **Hot Cue:** Press this button to enter Hot Cue Mode, and press it again to enter Stems mode.
Note: Stems support requires a one-time license purchase and activation. See [Stems Mode](#) for more information.
29. **Loop:** Press this button once to enter Manual Loop Mode, and press it again to enter Auto Loop Mode.
30. **Roll:** Press this button to enter Roll Mode, and press it again to enter Sampler Mode.
31. **Slicer:** Press this button once to enter Slicer Mode, and press it again to enter Slicer Loop Mode.
32. **Parameter ◀/▶:** Use these buttons for various functions in certain Pad Modes. See [Pad Modes](#) for more information.
33. **Loop In/Loop Out:** Press either of these buttons to create a Loop In or Loop Out point at the current location. Their placement will be affected by the **Quantize** and **Smart Loops** settings. See [Control Center](#) for more information.
34. **Auto Loop/Loop Move:** Turn this knob to set the size of an automatic loop. The value will be shown in the touchscreen and platter display.
Press this knob to activate or deactivate an automatic loop at the current location of the track.
Tip: You can assign auto loops to pads in Manual Loop Mode. See [Pad Modes](#) for more information.
Press and hold **Shift** and turn this knob to shift the active loop to the left or right.
35. **Beat Jump:** Press either of these buttons to skip backward or forward through the track.
Press and hold **Shift** and then press one of these buttons to increase or decrease the beat jump size.

Front Panel

1. **Front USB Port:** Connect a standard USB drive to this USB port. When you select that USB drive as a source (press the **Source** button), you can select and load tracks from it. There are also two similar USB ports on the rear panel. You can use the included USB extension cable to accommodate larger or smaller USB thumb drives.
2. **SD Card Slot:** Insert a standard SD card to this slot. When you select that SD card as a source (press the **Source** button), you can select and load tracks from it.

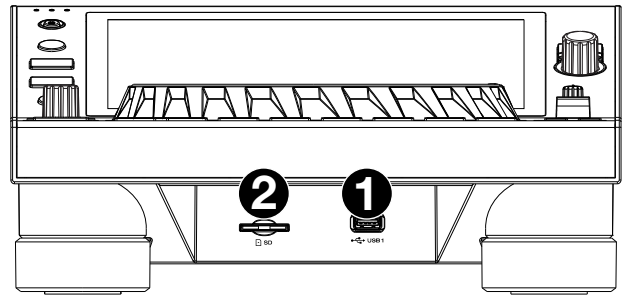

Rear Panel

1. **Power Input:** Use the included locking power cable to connect this input to a power outlet. To remove the power cable, push down on the yellow tab and then pull the cable out of the input. You can also use a standard IEC power cable in place of the included locking power cable.
SC6000 PRIME has a protection circuit to safely eject all media after an unexpected power loss to protect your data from corruption. Reconnect your power source to return to normal operation.

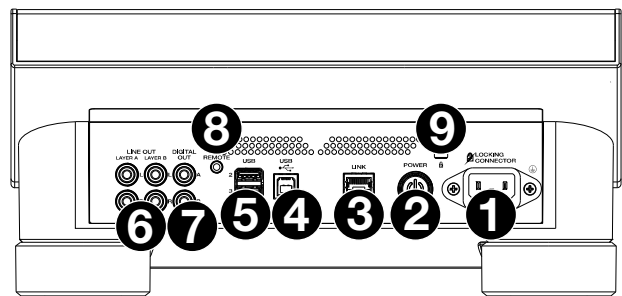

2. **Power Button:** Press this button to power SC6000 PRIME on or off. Power on SC6000 PRIME only **after** you have connected all of your input devices and **before** you power on your amplifiers and loudspeakers. Power off your amplifiers and loudspeakers **before** powering off SC6000 PRIME. Press and hold this button for 10 seconds to reset SC6000 PRIME.
3. **Link Port:** Use the included networking cable to connect this port to another SC6000 PRIME or to your Denon DJ mixer. Each networked SC6000 PRIME can share track databases, timing and BPM information, and other track data over this connection. You can also connect this port to an internet access point such as a router for a hardwired internet connection.
4. **USB B Port:** Use a standard USB cable (included) to connect this USB port to an available USB port on your computer. This connection sends and receives MIDI messages to and from the computer.
5. **Rear USB Ports 2/3:** Connect standard USB drives to these USB ports. When you select one of those USB drives as a source (press the **Source** button), you can select and load tracks from it. There is also a similar USB port on the front panel.
6. **Layer A/B Outputs:** Use standard RCA cables to connect these outputs to your DJ mixer. The **Layer A** Line Outputs send out the audio signal from Layer A. The **Layer B** Line Outputs send out the audio signal from Layer B.
7. **Digital Outputs A/B:** Use standard digital coaxial cables to connect these 24-bit/96 kHz outputs to devices and mixers such as the Denon DJ X1850 PRIME.
8. **Remote Input:** Use a standard remote start cable to connect this input to the remote-start output of your mixer (if available). While connected to a remote-start-compatible mixer, moving the crossfader toward the side that corresponds to this SC6000 PRIME (or raising the channel fader for its channel) will automatically start the track on the currently selected layer.
9. **Kensington® Lock Slot:** Use this slot to secure SC6000 PRIME to a table or other surface.

SC6000M PRIME

Top Panel

Media Selection & Browsing

- Touchscreen:** This full-color multi-touch display shows information relevant to SC6000M PRIME's current operation. Touch the display (and use the hardware controls) to control the interface. See [Touchscreen Overview](#) for more information.
- Media Selection:** These lights will illuminate to indicate if the corresponding type of media is connected: **USB**, **SD**, or **Link**.
- Source:** Press this button to show a list of available devices connected to SC6000M PRIME in the touchscreen (other networked SC6000M PRIME units, USB drives, SD card, Wi-Fi, etc.). Tap a device in the list to select it.

- Media Eject:** Press this button to show a list of devices connected to that SC6000M PRIME unit in the **touchscreen** (i.e., USB drives connected to its USB ports or an SD card inserted into its SD card slot).

To eject a device, make sure none of its tracks are being played, and then tap the **Eject** icon on the **touchscreen** and follow the prompts.

- Back:** While in [Library View](#), press this button to move to the previous window. While in [Performance View](#), press this button to enter Library View.

- Forward:** While in Library View, press this button to move to the next window. While in Performance View, press this button to enter Library View.
- Select/Load (Browse) / Zoom:** In Performance View, turn this knob to open Library View and navigate through lists.

Note: Alternatively, you can change the default **Encoder Behavior** for this knob to adjust the waveform zoom level in the [Settings > Device](#) menu.

Press the knob to move forward in the touchscreen, select an item, or load a track to a selected deck. Double-press the knob to load a track to both layers ("instant doubles").

Press and hold the knob to adjust the beat grid (see [Beat Grid Editing](#) for more details on adjusting the beat grid).

Press and hold **Shift** and then press and hold this knob to manually adjust cue/loop point locations left or right using the **touchscreen** controls.

- View / Preferences/Utility:** Press this button to switch between [Library View](#) and [Performance View](#). Double-press this button to enter the [Engine Lighting](#) view. Press and hold this button to enter the [Control Center](#) menu.

In Performance View, hold **Shift** and press the **View** button to cycle between **View 1–3** layout presets, which can be customized in the [Layout](#) menu. In Library View, hold **Shift** and press the **View** button to open or close the collection panel while the track list is in focus.

- Shortcuts:** Press this button to open the [Control Center](#), which includes quick links to other menus such as Source, Profile and Settings.

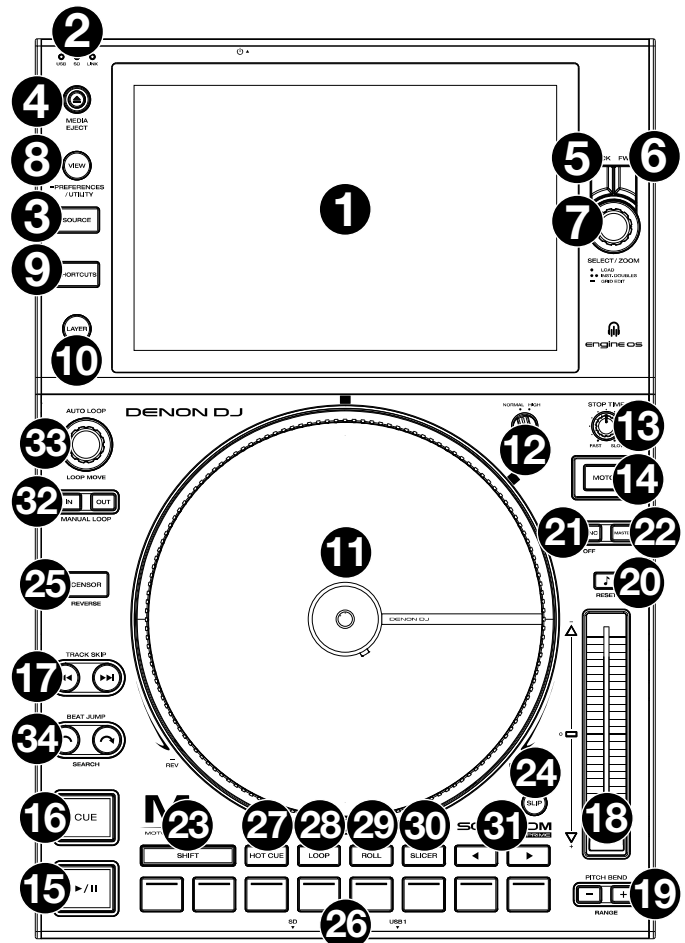

Playback & Transport Controls

10. **Layer:** Press this button to switch the layer focus of the SC6000M PRIME.
Press and hold **Shift** and press this button to toggle between Single and Dual Layer views.
Note: This button will be disabled if the **Layer B** option under [Layout > Deck Behavior](#) is set to **Off**.
11. **Platter:** This motorized platter controls the audio playhead in the software. It can be used to scratch and spin or act as a static pitch platter depending on the setting of the **Motor** button.
12. **Torque Adjust:** Flip this rotary switch to adjust the torque of the **platters**. At the **high** setting, the platters will have the heavier, stronger feel of “modern” turntables. At the **normal** setting, they are lighter and more graceful—the feel of a “classic” turntable.
13. **Stop Time:** Controls the rate at which the track slows to a complete stop (“brake time”) when you pause it by pressing **Play/Pause** (▶/||).
14. **Motor:** Press this button to activate or deactivate the platter motor. When the motor is activated, the platter will spin and scratch like a turntable.
When the motor is deactivated and audio is playing, move the **platter** to temporarily adjust the track’s speed, which is useful for beat alignment. When deactivated and audio is paused, move the **platter** to scratch the track. Audio will not be interrupted if the motor is activated during playback.
15. **Play/Pause** (▶/||): This button pauses or resumes playback.
Press and hold **Shift** and then press this button to “stutter-play” the track from the initial cue point.
16. **Cue:** During playback, press this button to return the track to the initial cue point and stop playback.
To move the initial cue point while the track is paused, move the **platter** to place the audio playhead at the desired location, and then press this button. Alternatively, if the track is playing, press and hold **Shift** and then press this button to set the initial cue point at the current playhead position.
If the deck is paused, press and hold this button to temporarily play the track from the initial cue point. Release the button to return the track to the initial cue point and pause it. To continue playback without returning to the initial cue point, press and hold this button and then press and hold the **Play** button, and then release both buttons.
17. **Track Skip:** Press either of these buttons to skip to the previous or next track.
Press the **Previous Track** button in the middle of a paused track to return to the beginning of the track.
Press and hold **Shift** and then press one of these buttons to search backward or forward through the track.

Sync & Pitch Controls

18. **Pitch Fader:** Move this fader to adjust the speed (pitch) of the track. You can adjust its total range by pressing and holding **Shift** and pressing one of the **Pitch Bend** buttons.
Important: If Sync is activated, moving the pitch fader on the “primary” SC6000M PRIME unit will change the speed of all synced units, while moving the pitch fader on other units will do nothing.
19. **Pitch Bend –/+:** Press and hold one of these buttons to momentarily reduce or increase (respectively) the speed of the track.
Press and hold **Shift** and then press one of these buttons to set the range of the pitch fader.
20. **Key Lock/Reset:** Press this button to activate or deactivate Key Lock. When Key Lock is activated, the track’s key will remain the same even if you adjust its speed.
Press and hold **Shift** and press this button to reset the track to its original key regardless of the position of the **pitch fader** or edits made via key change menu.
21. **Sync/Sync Off:** Press this button to activate Sync.
To sync two or more PRIME units, press **Sync** on the unit that you want to control the BPM, which becomes the “primary.” After Sync is activated on that unit, press **Sync** on any additional units. The units will immediately synchronize according to the Sync Mode setting in the [Profile > Playback](#) menu.
To deactivate Sync, press the **Sync** button again, or press and hold **Shift** and press **Sync**, depending on the **Sync Button Action** setting in the [Profile > Playback](#) menu.
22. **Master:** Press this button to set this SC6000M PRIME unit as the one that controls the lead tempo. All connected units with Sync activated will use this tempo. If you stop the sync lead unit, the next-longest-playing unit in the setup will automatically become the new sync lead (unless you change it manually).

Performance Controls

23. **Shift:** Press and hold this button to access secondary functions of other controls.
24. **Slip:** Press this button to enable or disable Slip Mode. In Slip Mode, you can jump to cue points, use the platter, or pause the track while the track's timeline continues (half of the waveform in the display will continue moving forward). In other words, when you stop whatever action you are performing, the track will resume normal playback from where it would have been if you had never done anything (i.e., as if the track had been playing forward the whole time).
25. **Censor/Reverse:** Press this button to activate the Censor feature: the playback of the track will be reversed, but when you release the button, normal playback will resume from where it would have been if you had never engaged the Censor feature (i.e., as if the track had been playing forward the whole time).
Press and hold **Shift** and then press this button to reverse the playback of the track normally. Press this button again to return playback to the normal forward direction.
26. **Performance Pads:** These pads have different functions depending on the current pad mode. See [Pad Modes](#) for more information.
27. **Hot Cue:** Press this button to enter Hot Cue Mode, and press it again to enter Stems mode.
Note: Stems support requires a one-time license purchase and activation. See [Stems Mode](#) for more information.
28. **Loop:** Press this button once to enter Manual Loop Mode, and press it again to enter Auto Loop Mode.
29. **Roll:** Press this button to enter Roll Mode, and press it again to enter Sampler Mode.
30. **Slicer:** Press this button once to enter Slicer Mode, and press it again to enter Slicer Loop Mode.
31. **Parameter ◀/▶:** Use these buttons for various functions in certain Pad Modes. See [Pad Modes](#) for more information.
32. **Loop In/Loop Out:** Press either of these buttons to create a Loop In or Loop Out point at the current location. Their placement will be affected by the **Quantize** and **Smart Loops** settings. See [Control Center](#) for more information.
33. **Auto Loop/Loop Move:** Turn this knob to set the size of an automatic loop. The value will be shown in the touchscreen.
Press this knob to activate or deactivate an automatic loop at the current location of the track.
Tip: You can assign auto loops to pads in Manual Loop Mode. See [Pad Modes](#) for more information.
Press and hold **Shift** and turn this knob to shift the active loop to the left or right.
34. **Beat Jump:** Press either of these buttons to skip backward or forward through the track.
Press and hold **Shift** and then press one of these buttons to increase or decrease the beat jump size.

Front Panel

1. **Front USB Port:** Connect a standard USB drive to this USB port. When you select that USB drive as a source (press the **Source** button), you can select and load tracks from it. There are also two similar USB ports on the rear panel. You can use the included USB extension cable to accommodate larger or smaller USB thumb drives.
2. **SD Card Slot:** Insert a standard SD card to this slot. When you select that SD card as a source (press the **Source** button), you can select and load tracks from it.

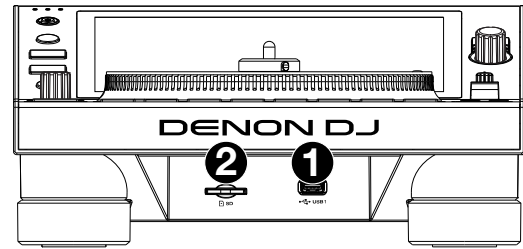

Rear Panel

1. **Power Input:** Use the included locking power cable to connect this input to a power outlet. To remove the power cable, push down on the yellow tab and then pull the cable out of the input. You can also use a standard IEC power cable in place of the included locking power cable.
SC6000M PRIME has a protection circuit to safely eject all media after an unexpected power loss to protect your data from corruption. Reconnect your power source to return to normal operation.

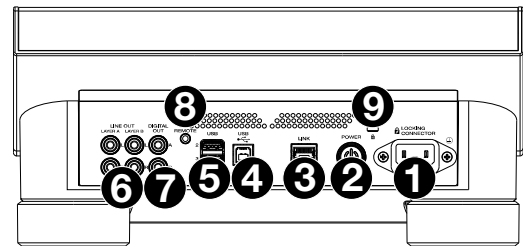

2. **Power Button:** Press this button to power SC6000M PRIME on or off. Power on SC6000M PRIME only **after** you have connected all of your input devices and **before** you power on your amplifiers and loudspeakers. Power off your amplifiers and loudspeakers **before** powering off SC6000M PRIME. Press and hold this button for 10 seconds to reset SC6000M PRIME.
3. **Link Port:** Use the included networking cable to connect this port to another SC6000M PRIME or to your Denon DJ mixer. Each networked SC6000M PRIME can share track databases, timing and BPM information, and other track data over this connection. You can also connect this port to an internet access point such as a router for a hardwired internet connection.
4. **USB B Port:** Use a standard USB cable (included) to connect this USB port to an available USB port on your computer. This connection sends and receives MIDI messages to and from the computer.
5. **Rear USB Ports 2/3:** Connect standard USB drives to these USB ports. When you select one of those USB drives as a source (press the **Source** button), you can select and load tracks from it. There is also a similar USB port on the front panel.
6. **Layer A/B Outputs:** Use standard RCA cables to connect these outputs to your DJ mixer. The **Layer A** Line Outputs send out the audio signal from Layer A. The **Layer B** Line Outputs send out the audio signal from Layer B.
7. **Digital Outputs A/B:** Use standard digital coaxial cables to connect these 24-bit/96 kHz outputs to devices and mixers such as the Denon DJ X1850 PRIME mixer.
8. **Remote Input:** Use a standard remote start cable to connect this input to the remote-start output of your mixer (if available). While connected to a remote-start-compatible mixer, moving the crossfader toward the side that corresponds to this SC6000M PRIME (or raising the channel fader for its channel) will automatically start the track on the currently selected layer.
9. **Kensington® Lock Slot:** Use this slot to secure SC6000M PRIME to a table or other surface.

SC5000 PRIME

Top Panel

Media Selection & Browsing

- Touchscreen:** This full-color multi-touch display shows information relevant to SC5000 PRIME's current operation. Touch the display (and use the hardware controls) to control the interface. See [Touchscreen Overview](#) for more information.
- Media Selection:** These lights will illuminate to indicate if the corresponding type of media is connected: **USB**, **SD**, or **Network**.
- Source:** Press this button to show a list of available devices connected to SC5000 PRIME in the touchscreen (other networked SC5000 PRIME units, USB drives, SD card, etc.). Tap a device in the list to select it.
- Media Eject:** Press this button to show a list of available devices connected to that SC5000 PRIME unit in the **touchscreen** (i.e., USB drives connected to its USB ports, or an SD card inserted into its SD card slot).

To eject a device, make sure none of its tracks are being played, and then tap the **Eject** icon on the **touchscreen** and follow the prompts.

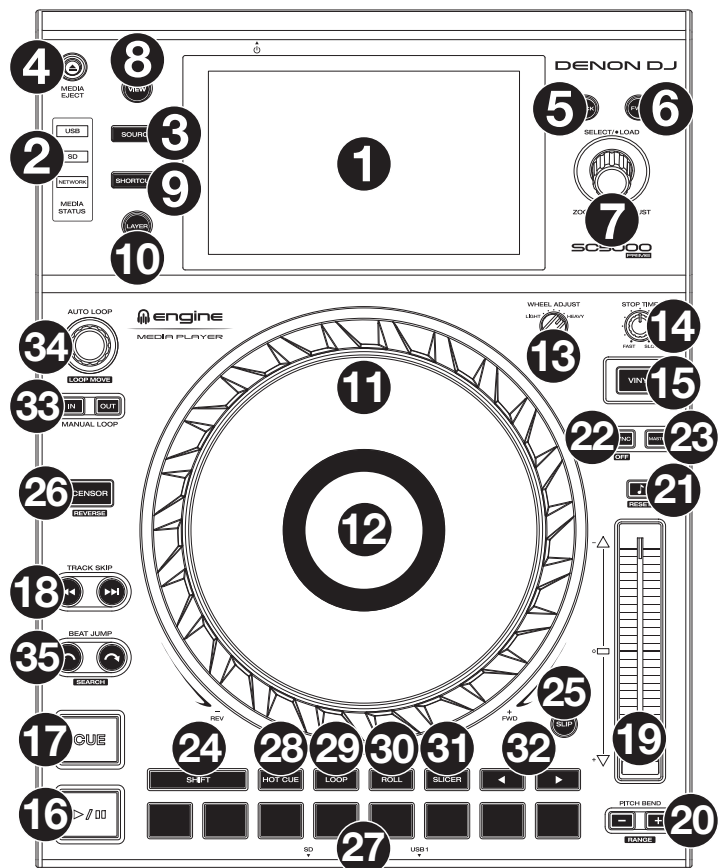

- Back:** While in [Library View](#), press this button to move to the previous window. While in [Performance View](#), press this button to enter Library View.
- Forward:** While in Library View, press this button to move to the next window. While in Performance View, press this button to enter Library View.
- Select/Load (Browse) / Zoom:** In Performance View, turn this knob to open Library View and navigate through lists.

Note: Alternatively, you can change the default **Encoder Behavior** for this knob to adjust the waveform zoom level in the [Settings > Device](#) menu.

Press the knob to move forward in the touchscreen, select an item, or load a track to a selected deck. Double-press the knob to load a track to both layers ("instant doubles").

Press and hold the knob to adjust the beat grid (see [Beat Grid Editing](#) for more details on adjusting the beat grid).

Press and hold **Shift** and then press and hold this knob to manually adjust cue/loop point locations left or right using the **touchscreen** controls.

- View / Preferences/Utility:** Press this button to switch between [Library View](#) and [Performance View](#). Double-press this button to enter the [Engine Lighting](#) view. Press and hold this button to enter the [Control Center](#) menu.

In Performance View, hold **Shift** and press the **View** button to cycle between **View 1–3** layout presets, which can be customized in the [Layout](#) menu. In Library View, hold **Shift** and press the **View** button to open or close the collection panel while the track list is in focus.

- Shortcuts:** Press this button to open the [Control Center](#), which includes quick links to other menus such as Source, Profile and Settings.

Playback & Transport Controls

10. **Layer:** Press this button to switch the layer focus of the SC5000 PRIME.
Press and hold **Shift** and press this button to toggle between Single and Dual Layer views.
Note: This button will be disabled if the **Layer B** option under [Layout > Deck Behavior](#) is set to **Off**.
11. **Platter:** This capacitive, touch-sensitive platter controls the audio playhead when the wheel is touched and moved. When the **Vinyl** button is on, move the **platter** to “scratch” the track as you would with a vinyl record. When the **Vinyl** button is off (or if you are touching only the side of the **platter**), move the **platter** to temporarily adjust the track’s speed.
12. **Platter Display:** This display shows information relevant to the performance, including the current playhead position and auto loop size, as well as album artwork. See [Platter Display Overview](#) for more information.
13. **Wheel Adjust:** Turn this knob to set how resistant the platter is to adjustments. This knob applies a brake to the platter to prevent unintentional drifting due to environmental vibrations from bass frequencies, surface instability, etc.
14. **Stop Time:** Controls the rate at which the track slows to a complete stop (“brake time”) when you pause it by pressing **Play/Pause** (▶/||).
15. **Vinyl:** Press this button to activate or deactivate a “vinyl mode” for the platter. When activated, move the **platter** to “scratch” the track as you would with a vinyl record. When deactivated, move the **platter** to temporarily adjust the track’s speed, which is useful for beat alignment.
16. **Play/Pause** (▶/||): This button pauses or resumes playback.
Press and hold **Shift** and then press this button to “stutter-play” the track from the initial cue point.
17. **Cue:** During playback, press this button to return the track to the initial cue point and stop playback.
To move the initial cue point while the track is paused, move the **platter** to place the audio playhead at the desired location, and then press this button. Alternatively, if the track is playing, press and hold **Shift** and then press this button to set the initial cue point at the current playhead position.
If the deck is paused, press and hold this button to play the track from the initial cue point. Release the button to return the track to the initial cue point and pause it. To continue playback without returning to the initial cue point, press and hold this button and then press and hold the **Play** button, and then release both buttons.
18. **Track Skip:** Press either of these buttons to skip to the previous or next track. Press the **Previous Track** button in the middle of a track to return to the beginning of the track.
Press and hold **Shift** and then press one of these buttons to search backward or forward through the track.

Sync & Pitch Controls

19. **Pitch Fader:** Move this fader to adjust the speed (pitch) of the track. You can adjust its total range by pressing and holding **Shift** and pressing one of the **Pitch Bend** buttons.
Important: If Sync is activated, moving the pitch fader on the “primary” SC5000 PRIME unit will change the speed of all synced units, while moving the pitch fader on other units will do nothing.
20. **Pitch Bend** –/+ : Press and hold one of these buttons to momentarily reduce or increase (respectively) the speed of the track.
Press and hold **Shift** and then press one of these buttons to set the range of the pitch fader.
21. **Key Lock / Pitch Reset:** Press this button to activate or deactivate Key Lock. When Key Lock is activated, the track’s key will remain the same even if you adjust its speed.
Press and hold **Shift** and press this button to reset the track’s pitch to its original pitch (0%) regardless of the position of the pitch fader.

22. **Sync/Sync Off:** Press this button to activate Sync. To sync two or more PRIME units, press **Sync** on the unit that you want to control the BPM, which becomes the “primary.” After Sync is activated on that unit, press **Sync** on any additional units. The units will immediately synchronize according to the Sync Mode setting in the [Profile > Playback](#) menu.

To deactivate Sync, press the **Sync** button again, or press and hold **Shift** and press **Sync**, depending on the **Sync Button Action** setting in the [Profile > Playback](#) menu.

23. **Master:** Press this button to set this SC5000 PRIME unit as the one that controls the lead tempo. All connected units with Sync activated will use this tempo. If you stop the sync lead unit, the next-longest-playing unit in the setup will automatically become the new sync lead (unless you change it manually).

Performance Controls

24. **Shift:** Press and hold this button to access secondary functions of other controls.
25. **Slip:** Press this button to enable or disable Slip Mode. In Slip Mode, you can jump to cue points, use the platters, or pause the track while the track’s timeline continues (half of the waveform in the display will continue moving forward). In other words, when you stop whatever action you are performing, the track will resume normal playback from where it would have been if you had never done anything (i.e., as if the track had been playing forward the whole time).
26. **Censor / Reverse:** Press this button to activate the Censor feature: the playback of the track will be reversed, but when you release the button, normal playback will resume from where it would have been if you had never engaged the Censor feature (i.e., as if the track had been playing forward the whole time).

Press and hold **Shift** and then press this button to reverse the playback of the track normally. Press this button again to return playback to the normal forward direction.

27. **Performance Pads:** These pads have different functions on each deck depending on the current pad mode. See [Pad Modes](#) for more information.
28. **Hot Cue:** Press this button to enter Hot Cue Mode, and press it again to enter Stems mode.

Note: Stems support requires a one-time license purchase and activation. See [Stems Mode](#) for more information.

29. **Loop:** Press this button once to enter Manual Loop Mode. Press it once more to enter Auto Loop Mode.
30. **Roll:** Press this button to enter Roll Mode, and press it again to enter Sampler Mode.
31. **Slicer:** Press this button to enter Slicer Mode and press it again to enter Slicer Loop Mode.
32. **Parameter ◀/▶:** Use these buttons for various functions in certain Pad Modes. See [Pad Modes](#) for more information.
33. **Loop In/Loop Out:** Press either of these buttons to create a Loop In or Loop Out point at the current location. Their placement will be affected by the **Quantize** and **Smart Loops** settings. See [Control Center](#) for more information.

34. **Auto Loop / Loop Move:** Turn this knob to set the size of an automatic loop. The value will be shown in the touchscreen and platter display. Press this knob to activate or deactivate an automatic loop at the current location of the track.

Tip: You can assign auto loops to pads in Manual Loop Mode. See [Pad Modes](#) for more information.

Press and hold **Shift** and turn this knob to shift the active loop to the left or right.

35. **Beat Jump:** Press either of these buttons to skip backward or forward through the track.

Press and hold **Shift** and then press one of these buttons to increase or decrease the beat jump size.

Front Panel

1. **Front USB Port:** Connect a standard USB drive to this USB port. When you select that USB drive as a source (press the **Source** button), you can select and load tracks from it. There are also two similar USB ports on the rear panel. You can use the included USB extension cable to accommodate larger or smaller USB thumb drives.
2. **SD Card Slot:** Insert a standard SD or SDHC card to this slot. When you select that SD card as a source (press the **Source** button), you can select and load tracks from it.

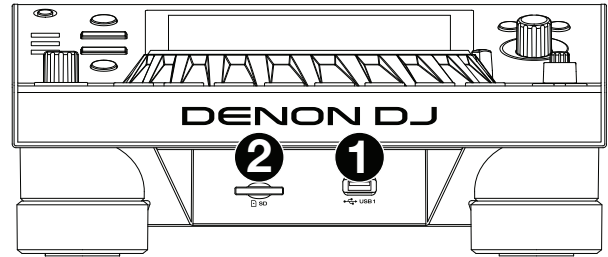

Rear Panel

1. **Power Input:** Use the included power cable to connect this input to a power outlet.
SC5000 PRIME has a protection circuit to safely eject all media after an unexpected power loss to protect your data from corruption. Reconnect your power source to return to normal operation.
2. **Power Button:** Press this button to power SC5000 PRIME on or off. Power on SC5000 PRIME only **after** you have connected all of your input devices and **before** you power on your amplifiers and loudspeakers. Power off your amplifiers and loudspeakers **before** powering off SC5000 PRIME. Press and hold this button for 10 seconds to reset SC5000 PRIME.
3. **Link Port:** Use the included networking cable to connect this port to another SC5000 PRIME or to your Denon DJ mixer. Each networked SC5000 PRIME can share track databases, timing and BPM information, and other track data over this connection. You can also connect this port to an internet access point such as a router for a hardwired internet connection.
4. **USB Port to PC (USB Out):** Use a standard USB cable (included) to connect this USB port to an available USB port on your computer. This connection sends and receives MIDI messages to and from the computer.
5. **Rear USB Ports 2/3:** Connect standard USB drives to these USB ports. When you select one of those USB drives as a source (press the **Source** button), you can select and load tracks from it. There is also a similar USB port on the front panel.
6. **Layer A/B Outputs:** Use standard RCA cables to connect these outputs to your DJ mixer. The **A** Line Outputs send out the audio signal from Layer A. The **B** Line Outputs send out the audio signal from Layer B.
7. **Digital Outputs A/B:** Use standard digital coaxial cables to connect these 24-bit/96 kHz outputs to devices and mixers such as the Denon DJ X1850 PRIME mixer.
8. **Remote Input:** Use a standard remote start cable to connect this input to the remote-start output of your mixer (if available). While connected to a remote-start-compatible mixer, moving the crossfader toward the side that corresponds to this SC5000 PRIME (or raising the channel fader for its channel) will automatically start the track on the currently selected layer.
9. **Kensington® Lock Slot:** Use this slot to secure SC5000 PRIME to a table or other surface.

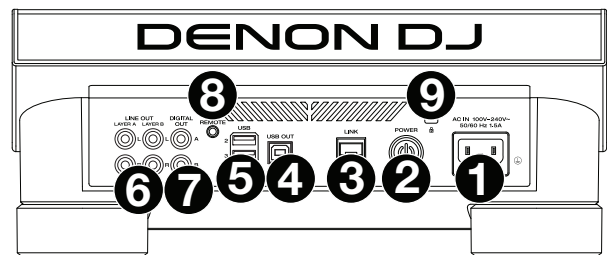

SC5000M PRIME

Top Panel

Media Selection & Browsing

- Touchscreen:** This full-color multi-touch display shows information relevant to SC5000M PRIME's current operation. Touch the display (and use the hardware controls) to control the interface. See [Touchscreen Overview](#) for more information.
- Media Selection:** These lights will illuminate to indicate if the corresponding type of media is connected: **USB**, **SD**, or **Network**.
- Source:** Press this button to show a list of available devices connected to SC5000M PRIME in the touchscreen (other networked SC5000M PRIME units, USB drives, SD card, etc.). Tap a device in the list to select it.
- Media Eject:** Press this button to show a list of available devices connected to that SC5000M PRIME unit in the **touchscreen** (i.e., USB drives connected to its USB ports, or an SD card inserted into its SD card slot).

To eject a device, make sure none of its tracks are being played, and then tap the **Eject** icon on the **touchscreen** and follow the prompts.

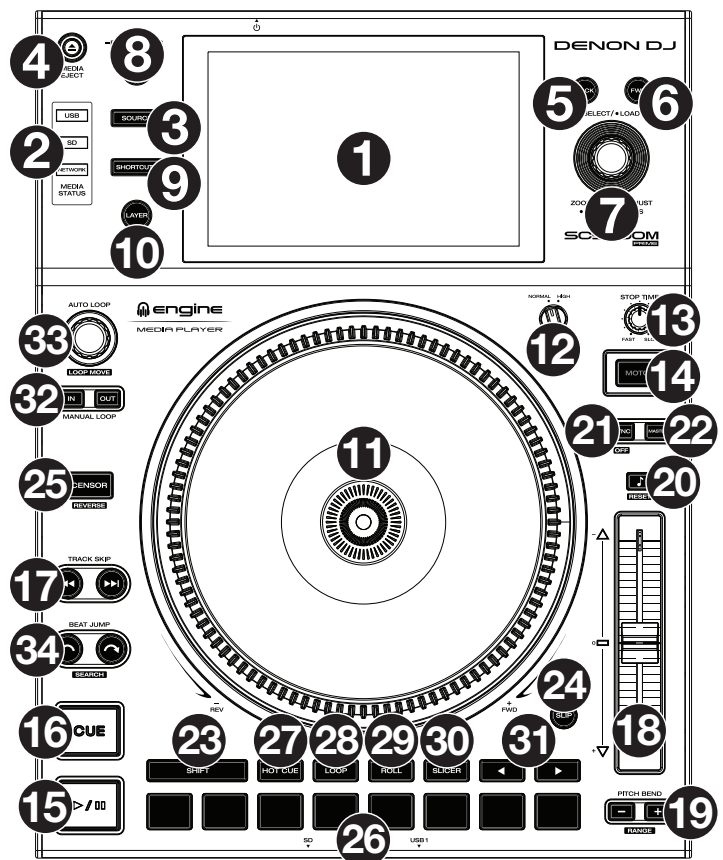

- Back:** While in [Library View](#), press this button to move to the previous window. While in [Performance View](#), press this button to enter Library View.
- Forward:** While in Library View, press this button to move to the next window. While in Performance View, press this button to enter Library View.
- Select/Load (Browse) / Zoom:** In Performance View, turn this knob to open Library View and navigate through lists.

Note: Alternatively, you can change the default **Encoder Behavior** for this knob to adjust the waveform zoom level in the [Settings > Device](#) menu.

Press the knob to move forward in the touchscreen, select an item, or load a track to a selected deck. Double-press the knob to load a track to both layers ("instant doubles").

Press and hold the knob to adjust the beat grid (see [Beat Grid Editing](#) for more details on adjusting the beat grid).

Press and hold **Shift** and then press and hold this knob to manually adjust cue/loop point locations left or right using the **touchscreen** controls.

- View / Preferences/Utility:** Press this button to switch between [Library View](#) and [Performance View](#). Double-press this button to enter the [Engine Lighting](#) view. Press and hold this button to enter the [Control Center](#) menu.

In Performance View, hold **Shift** and press the **View** button to cycle between **View 1–3** layout presets, which can be customized in the [Layout](#) menu. In Library View, hold **Shift** and press the **View** button to open or close the collection panel while the track list is in focus.

- Shortcuts:** Press this button to open the [Control Center](#), which includes quick links to other menus such as Source, Profile and Settings.

Playback & Transport Controls

10. **Layer:** Press this button to switch the layer focus of the SC5000M PRIME.
Press and hold **Shift** and press this button to toggle between Single and Dual Layer views.
Note: This button will be disabled if the **Layer B** option under **Layout > Deck Behavior** is set to **Off**.
11. **Platter:** This 7" motorized platter controls the audio playhead in the software, and can be used to scratch and spin or act as a static pitch platter depending on the setting of the **Motor** button.
12. **Torque Adjust:** Flip this rotary switch to adjust the torque of the **platters**. At the **High** setting, the platters will have the heavier, stronger feel of "modern" turntables. At the **Normal** setting, they are lighter and more graceful—the feel of a "classic" turntable.
13. **Stop Time:** Controls the rate at which the track slows to a complete stop ("brake time") when you pause it by pressing **Play/Pause** (▶/||).
14. **Motor:** Press this button to activate or deactivate the platter motor. When the motor is activated, the platter will spin and scratch like a turntable. When the motor is deactivated and audio is playing, move the **platter** to temporarily adjust the track's speed, which is useful for beat alignment. When deactivated and audio is paused, move the **platter** to scratch the track. Audio will not be interrupted if the motor is activated during playback.
15. **Play/Pause** (▶/||): This button pauses or resumes playback.
Press and hold **Shift** and then press this button to "stutter-play" the track from the initial cue point.
16. **Cue:** During playback, press this button to return the track to the initial cue point and stop playback. If you have not set a temporary cue point, then press this button to return to the start of the track.
To move the initial cue point while the track is paused, move the **platter** to place the audio playhead at the desired location, and then press this button. Alternatively, if the track is playing, press and hold **Shift** and then press this button to set the initial cue point at the current playhead position.
If the deck is paused, press and hold this button to play the track from the initial cue point. Release the button to return the track to the initial cue point and pause it. To continue playback without returning to the initial cue point, press and hold this button and then press and hold the **Play** button, and then release both buttons.
17. **Track Skip:** Press either of these buttons to skip to the previous or next track. Press the **Previous Track** button in the middle of a track to return to the beginning of the track.
Press and hold **Shift** and then press one of these buttons to search backward or forward through the track.

Sync & Pitch Controls

18. **Pitch Fader:** Move this fader to adjust the speed (pitch) of the track. You can adjust its total range by pressing and holding **Shift** and pressing one of the **Pitch Bend** buttons.
Important: If Sync is activated, moving the pitch fader on the "primary" SC5000M PRIME unit will change the speed of all synced units, while moving the pitch fader on other units will do nothing.
19. **Pitch Bend** -/+ : Press and hold one of these buttons to momentarily reduce or increase (respectively) the speed of the track.
Press and hold **Shift** and then press one of these buttons to set the range of the pitch fader.
20. **Key Lock / Pitch Reset:** Press this button to activate or deactivate Key Lock. When Key Lock is activated, the track's key will remain the same even if you adjust its speed.
Press and hold **Shift** and press this button to reset the track's pitch to its original pitch (0%) regardless of the position of the pitch fader.
21. **Sync/Sync Off:** Press this button to activate Sync. To sync two or more PRIME units, press **Sync** on the unit that you want to control the BPM, which becomes the "primary." After Sync is activated on that unit, press **Sync** on any additional units. The units will immediately synchronize according to the Sync Mode setting in the **Profile > Playback** menu.
To deactivate Sync, press the **Sync** button again, or press and hold **Shift** and press **Sync**, depending on the **Sync Button Action** setting in the **Profile > Playback** menu.
22. **Master:** Press this button to set this SC5000M PRIME unit as the one that controls the lead tempo. All connected units with Sync activated will use this tempo. If you stop the sync lead unit, the next-longest-playing unit in the setup will automatically become the new sync lead (unless you change it manually).

Performance Controls

23. **Shift:** Press and hold this button to access secondary functions of other controls.
24. **Slip:** Press this button to enable or disable Slip Mode. In Slip Mode, you can jump to cue points, use the platters, or pause the track while the track's timeline continues (half of the waveform in the display will continue moving forward). In other words, when you stop whatever action you are performing, the track will resume normal playback from where it would have been if you had never done anything (i.e., as if the track had been playing forward the whole time).
25. **Censor / Reverse:** Press this button to activate the Censor feature: the playback of the track will be reversed, but when you release the button, normal playback will resume from where it would have been if you had never engaged the Censor feature (i.e., as if the track had been playing forward the whole time).
- Press and hold **Shift** and then press this button to reverse the playback of the track normally. Press this button again to return playback to the normal forward direction.
26. **Performance Pads:** These pads have different functions on each deck depending on the current pad mode. See [Pad Modes](#) for more information.
27. **Hot Cue:** Press this button to enter Hot Cue Mode, and press it again to enter Stems mode.
- Note:** Stems support requires a one-time license purchase and activation. See [Stems Mode](#) for more information.
28. **Loop:** Press this button once to enter Manual Loop Mode, and press it again to enter Auto Loop Mode.
29. **Roll:** Press this button to enter Roll Mode, and press it again to enter Sampler Mode.
30. **Slicer:** Press this button to enter Slicer Mode, and press it again to enter Slicer Loop Mode.
31. **Parameter ◀/▶:** Use these buttons for various functions in certain Pad Modes. See [Pad Modes](#) for more information.
32. **Loop In/Loop Out:** Press either of these buttons to create a Loop In or Loop Out point at the current location. Their placement will be affected by the **Quantize** and **Smart Loops** settings. See [Control Center](#) for more information.
33. **Auto Loop / Loop Move:** Turn this knob to set the size of an automatic loop. The value will be shown in the touchscreen.
- Press this knob to activate or deactivate an automatic loop at the current location of the track.
- Tip:** You can assign auto loops to pads in Manual Loop Mode. See [Pad Modes](#) for more information.
- Press and hold **Shift** and turn this knob to shift the active loop to the left or right.
34. **Beat Jump:** Press either of these buttons to skip backward or forward through the track.
- Press and hold **Shift** and then press one of these buttons to increase or decrease the beat jump size.

Front Panel

1. **Front USB Port:** Connect a standard USB drive to this USB port. When you select that USB drive as a source (press the **Source** button), you can select and load tracks from it. There are also two similar USB ports on the rear panel. You can use the included USB extension cable to accommodate larger or smaller USB thumb drives.
2. **SD Card Slot:** Insert a standard SD or SDHC card to this slot. When you select that SD card as a source (press the **Source** button), you can select and load tracks from it.

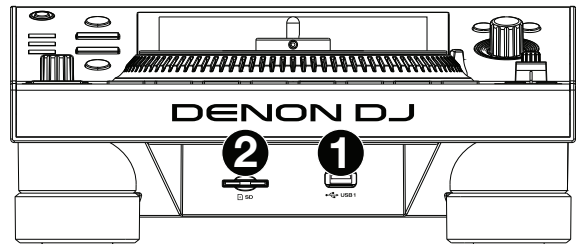

Rear Panel

1. **Power Input:** Use the included power cable to connect this input to a power outlet. SC5000M PRIME has a protection circuit to safely eject all media after an unexpected power loss to protect your data from corruption. Reconnect your power source to return to normal operation.
2. **Power Button:** Press this button to power SC5000M PRIME on or off. Power on SC5000M PRIME only **after** you have connected all of your input devices and **before** you power on your amplifiers and loudspeakers. Power off your amplifiers and loudspeakers **before** powering off SC5000M PRIME. Press and hold this button for 10 seconds to reset SC5000M PRIME.
3. **Link Port:** Use the included networking cable to connect this port to another SC5000M PRIME or to your Denon DJ mixer. Each networked SC5000M PRIME can share track databases, timing and BPM information, and other track data over this connection. You can also connect this port to an internet access point such as a router for a hardwired internet connection.
4. **USB Port to PC (USB Out):** Use a standard USB cable (included) to connect this USB port to an available USB port on your computer. This connection sends and receives MIDI messages to and from the computer.
5. **Rear USB Ports 2/3:** Connect standard USB drives to these USB ports. When you select one of those USB drives as a source (press the **Source** button), you can select and load tracks from it. There is also a similar USB port on the front panel.
6. **Layer A/B Outputs:** Use standard RCA cables to connect these outputs to your DJ mixer. The **A** Line Outputs send out the audio signal from Layer A. The **B** Line Outputs send out the audio signal from Layer B.
7. **Digital Outputs A/B:** Use standard digital coaxial cables to connect these 24-bit/96 kHz outputs to devices and mixers such as the Denon DJ X1850 PRIME mixer.
8. **Remote Input:** Use a standard remote start cable to connect this input to the remote-start output of your mixer (if available). While connected to a remote-start-compatible mixer, moving the crossfader toward the side that corresponds to this SC5000M PRIME (or raising the channel fader for its channel) will automatically start the track on the currently selected layer.
9. **Kensington® Lock Slot:** Use this slot to secure SC5000M PRIME to a table or other surface.

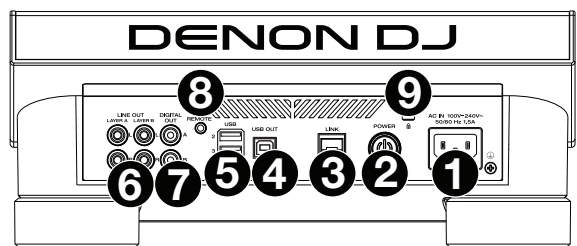

Operation

Touchscreen Overview

Performance View

Track Overview & Waveform

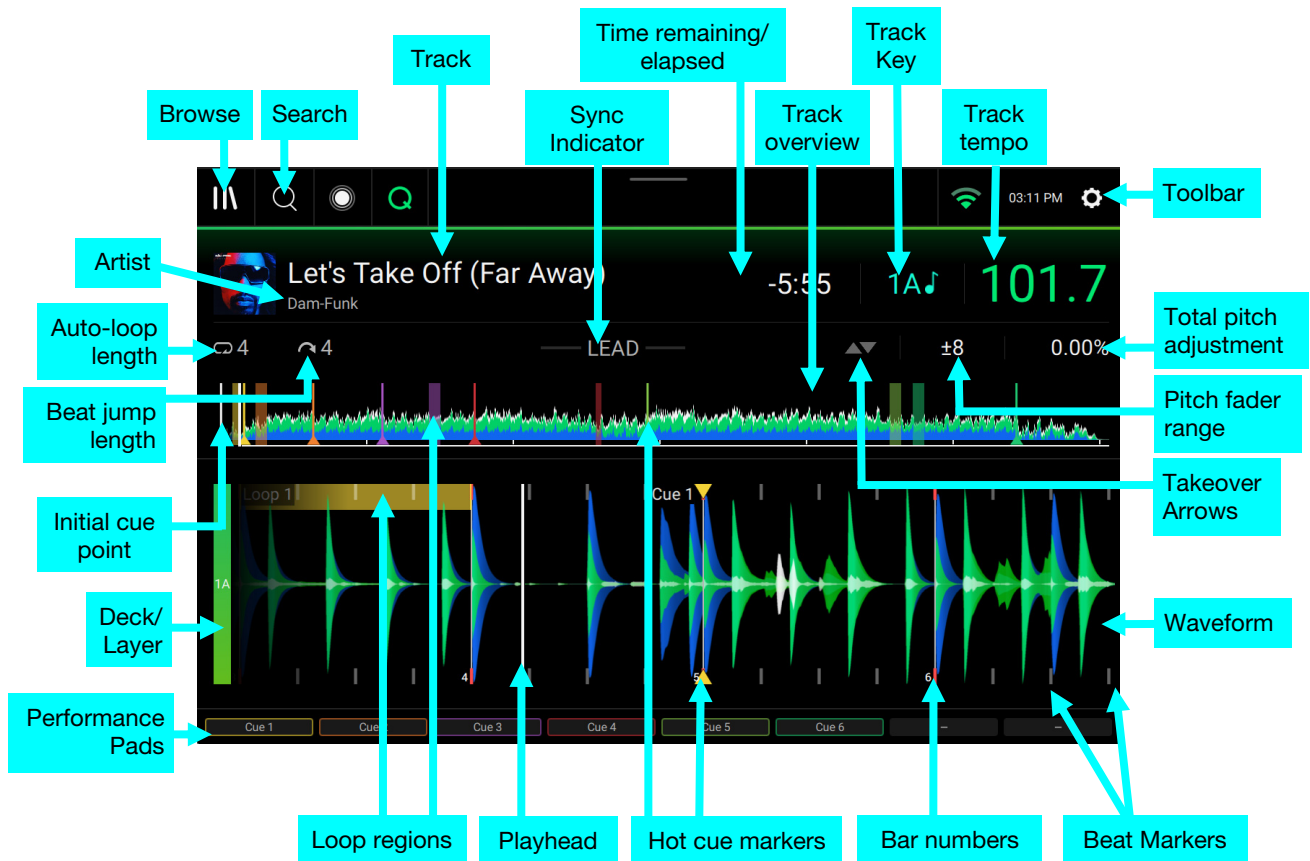

Swipe left or right on the **track overview** to scan through the track while the track is paused.

Note: You can use this feature during playback if Needle Lock is **off**. If Needle Lock is **on**, make sure the platter is in Vinyl Mode (press **Vinyl** so it is lit) and touch the top of the **platter** while swiping the track overview. See [Profile](#) to learn about Needle Lock.

Spread or pinch your fingers on the **waveform** to zoom in or out of it, respectively. Alternatively, turn the **Select/Zoom** knob (if the default **Encoder Behavior** for this knob is set to adjust the waveform zoom level in the [Settings > Device](#) menu).

Tap the time to switch between the elapsed time and remaining time.

Tap the key to show the Key Change Menu, where you can enable or disable Key Sync and adjust the key of the track. See [Syncing & Pitch Adjustment](#) for more information.

Tap the track artwork to open the track information window. In this window, tap the **star icons** at the bottom of the screen to add or change a track's star rating.

Tap the Q icon in the toolbar to enable or disable quantization.

Press and hold the Select/Zoom knob for a second to show or hide the beat grid controls. See [Beat Grid Editing](#) for more information.

Press and hold **Shift** and press the **View** button to cycle between **View 1–3** layout presets. Performance View layouts can be customized using the **Layout** menu.

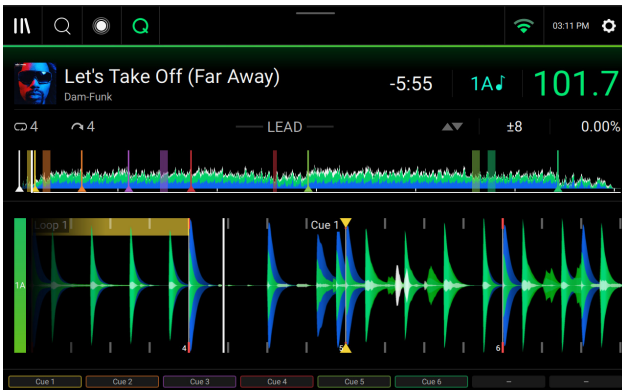

Layout 1: Single Layer, Horizontal Waveform with Performance Pads

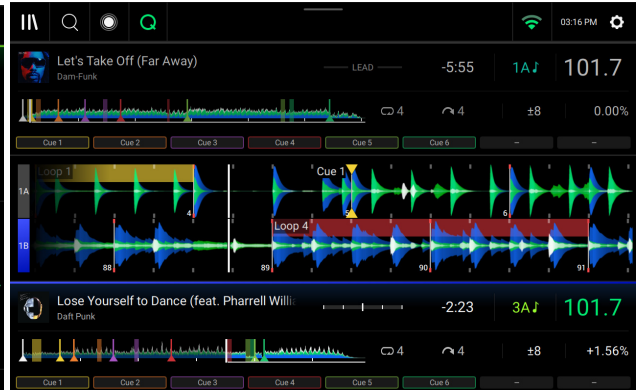

Layout 2: Dual (Stacked) Layers, Horizontal Waveforms with Performance Pads

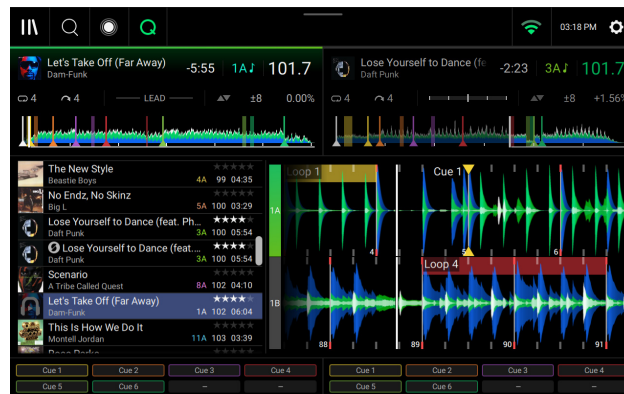

Layout 3: Dual (Grouped) Layers, Horizontal Waveforms with Performance Pads and Performance Library

Performance Library



The Performance Library can be enabled or disabled in the **Layout** menu of the Control Center. When the Performance Library is shown, you can do the following:

Swipe up or down to browse tracks.

Tap and drag the scroll bar to quickly browse through tracks.

Swipe left or right to load a track to the active layer. Alternatively, **swipe half-way to the left or right** and then **tap the Layer A/B button**.

Double-tap or swipe half-way to the right and then **tap the Load button** to load a track to a selected layer or sampler slot.

Tap the track art to preview the track. Tap again to stop previewing. While previewing, tap along the track entry to scan through the track. Track preview audio will be routed to the active layer if no tracks are loaded. If tracks are loaded to both layers, the preview audio will be routed to opposite layer of the active layer.

Tap and hold a track to view track information. In this window, tap the **star icons** at the bottom of the screen to add or change a track's star rating.

Toolbar

The **toolbar** at the top of the touchscreen features shortcuts to [Library View](#) and displays the status of certain hardware and feature settings. **Swipe down** from this area to open the [Control Center](#).



Browse: Tap the stacks icon to open the full [Library View](#) screen.

Search: Tap the magnifying glass icon to search for tracks using the keyboard that appears in the display.

Touch FX: Tap the target icon to open the [Touch FX](#) screen.

Q: Tap the Q icon to enable or disable quantization. When enabled, time-based features like triggering cues and loops will snap to the beat-grid according to the **Cue/Loop Quantization** setting in the [Profile > Cues Loops](#) menu.

Link: Shows the current Ableton Link status. Enabling Ableton Link will synchronize the beat, phase, and tempo of Ableton Live and your PRIME hardware over a wireless or wired network.

Continue: The figure-eight icon indicates Continue is enabled, which will keep playing the next track when the active track has ended.

Bluetooth: Shows the current Bluetooth connection status when Bluetooth is enabled. Tap here to open the [Bluetooth](#) connection menu.

Wi-Fi: Shows the current Wi-Fi connection status when Wi-Fi is enabled. Tap here to open the [Wi-Fi](#) connection menu.

Time: Displays the current local time. You can adjust the Time in the [Settings > Device](#) menu.

Control Center: Tap the gear icon to open the [Control Center](#).

Note: If your PRIME hardware rises above normal operating temperatures, an overheat warning will be displayed in the toolbar. Make sure to leave sufficient space around your device for ventilation. If overheating persists, shut down the unit and allow it to cool down to prevent damage.

Library View

Use the Library View to view your music library and load a track to the deck. You can also search through playlists, add tracks to the Prepare list, and search through your tracks using sorting and filtering features.

Important: Visit enginedj.com/downloads to download the Engine DJ software.

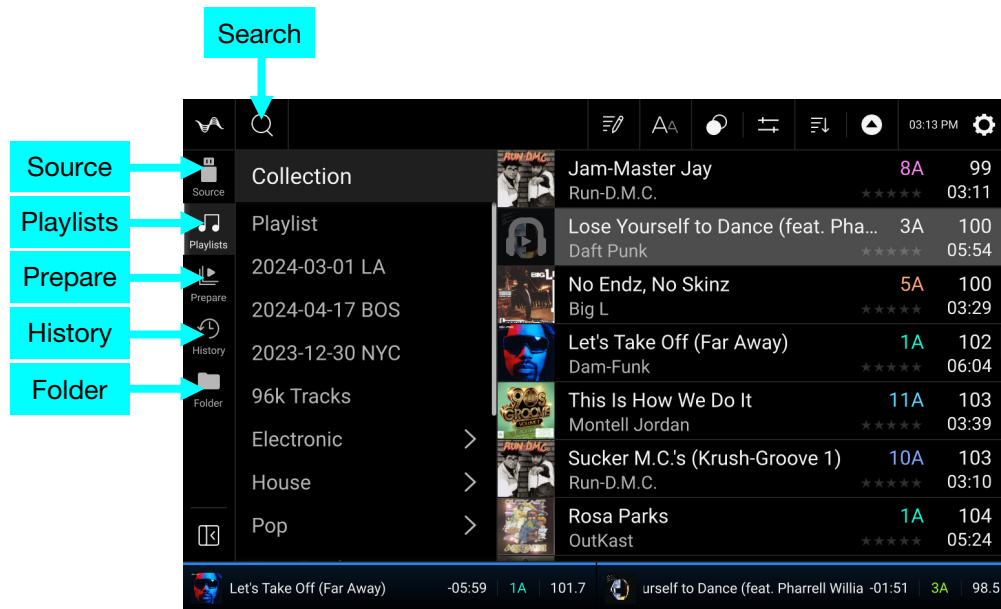

Tap the **magnifying glass** icon to search through your tracks by keyword. The search results are based on the album name, artist name, track name, key, and tempo. See [Searching & Filtering Tracks](#) for more information.

Use the five icons on the left side to navigate while in Library View:

- **Source:** Tap here to access the Quick Source Menu, where you can swap between connected sources to view and select tracks. Tap the **expand icon** to open the full [Source](#) menu, where you can connect to available streaming and cloud services, Engine Remote Libraries, and access pre-installed Demo and Sampler content. You can also enable or disable streaming and cloud services using the [Settings > Services](#) menu.
- **Playlists:** Your playlists are your collections of tracks, including lists of tracks arranged in a specific order. You may have playlists for different types of clubs or events, for specific genres, etc. You can create playlists to use here directly on your device (see [Editing Playlists](#)) or by using the included Engine DJ software.
- **Prepare:** You can load tracks to the Prepare list so that you can refer to them later when you want to play them during your performance (rather than searching through your entire library for the next track to play).
- **History:** Use this option to view your playback history.
- **Folder:** Use this option to browse the list of all files on a USB drive or SD card.

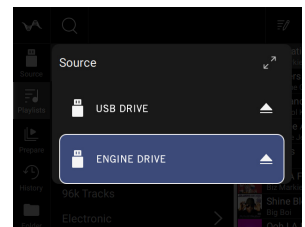

To close the collection panel while browsing a track list, tap the **close panel icon** at the bottom of the left side. Alternatively, press and hold **Shift** and press **View**.

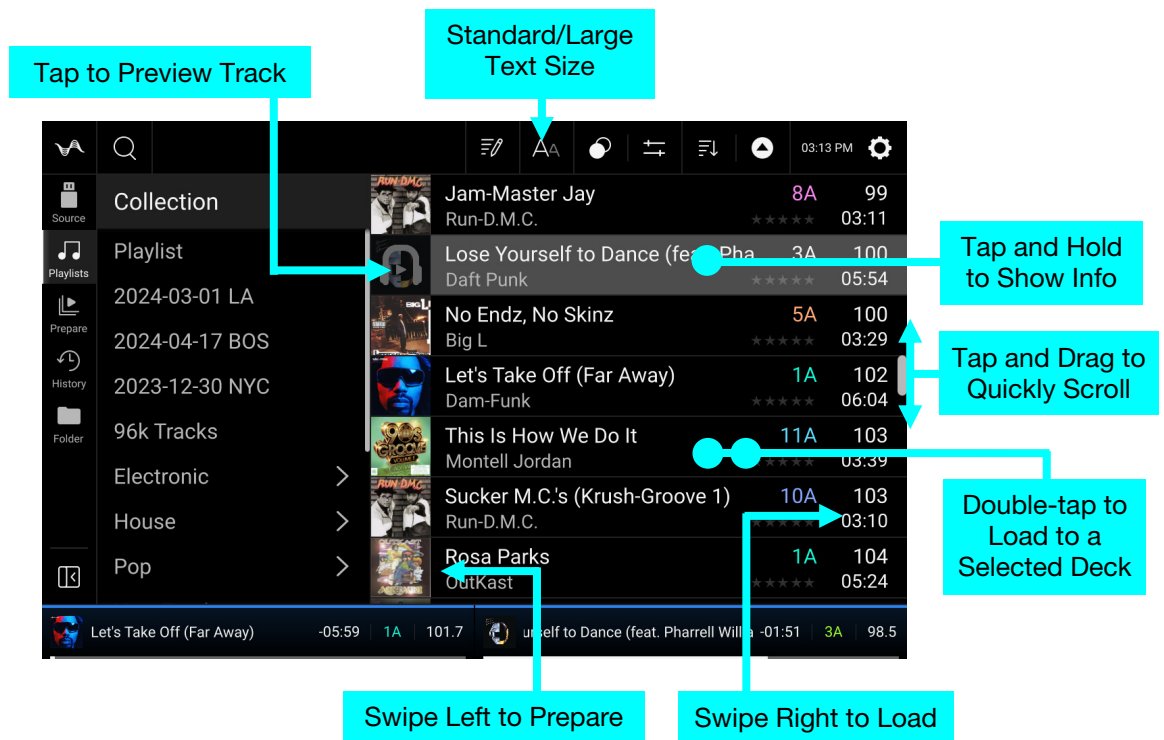

Tap the Standard/Large Track View icon (AA) at the top of the display to toggle between standard and large text sizes.

Swipe a list up or down to browse through it (e.g., your list of playlists or your list of tracks). Alternatively, press the **Back** or **Forward** buttons to select a list, and then turn the **Select/Zoom** knob. Press and hold **Shift** and turn the **Select/Zoom** knob to scroll quickly through the list. You can also tap and drag the scroll bar on the right edge of the list.

Tap an icon or item in a list to select it (e.g., the icons for Playlists, Prepare List, or Files on the left side of the Library). Alternatively, press the **Select/Zoom** knob.

Swipe a track to the left or right to load it to the active layer. Alternatively, **swipe half-way to the left or right** and then **tap the Layer A/B button**, or press the **Select/Zoom** knob.

Swipe a track half-way to the right and then tap **Load** to load it to a selected layer or sampler slot. Then, tap the desired layer or sample slot.

Alternatively, double-tap the track, then tap the layer or turn and press the **Select/Zoom** knob to select the desired layer.

Partially swipe a track to the left and tap **Prepare** to add it to the Prepare list. Alternatively, press and hold **Shift** and press the **Select/Zoom** knob. Swipe a track to the left in the Prepare list to remove it.

Tap and hold your finger on a track to show its information window (see image, right). In this window, tap the **star icons** at the bottom of the screen to add or change a track's star rating. Tap the X in the corner of the window to close it, or press the **Back** button. Turn the **Browse** knob to scroll through the current track list with the information window open.

Tap the track art to preview the track. Tap again to stop the preview. While previewing, tap along the track entry to scan through the track.

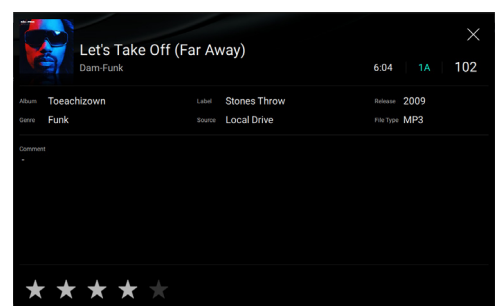

Platter Display Overview (SC6000/SC5000 PRIME only)

Normally, the platter display shows the following information:

- the current position of the playhead.
- the album artwork of the current track.

The platter display temporarily shows the following information:

- the current size of an auto loop after you turn the **Auto Loop** knob.
- the current beat jump size after you press **Shift** and one of the **Beat Jump** buttons to increase or decrease it.
- the current layer after you press the **Layer** button.
- the position of the secondary playhead when **Slip** is active.
- the track end warning when 30 seconds of playback remain.



Performing

Loading & Removing Tracks

While viewing any track list:

To load a track to the layer currently in focus on the deck, swipe the track to the left or right. Alternatively, swipe half-way to the left or right and then tap the Layer A/B button, or press the **Select/Zoom** knob.

To load a track to a selected layer or sampler slot, partially-swipe the track to the right, tap **Load**, and then select the layer or sampler slot. Alternatively, double-tap the track, then tap the layer or turn and press the **Select/Zoom** knob to select the desired layer.

To add a track to the Prepare list, partially-swipe the track to the left, and then tap **Prepare**. Alternatively, press and hold **Shift** and press the **Select/Zoom** knob.

To show a track's information, tap and hold your finger on it. In this window, tap the **star icons** at the bottom of the screen to add or change a track's star rating.

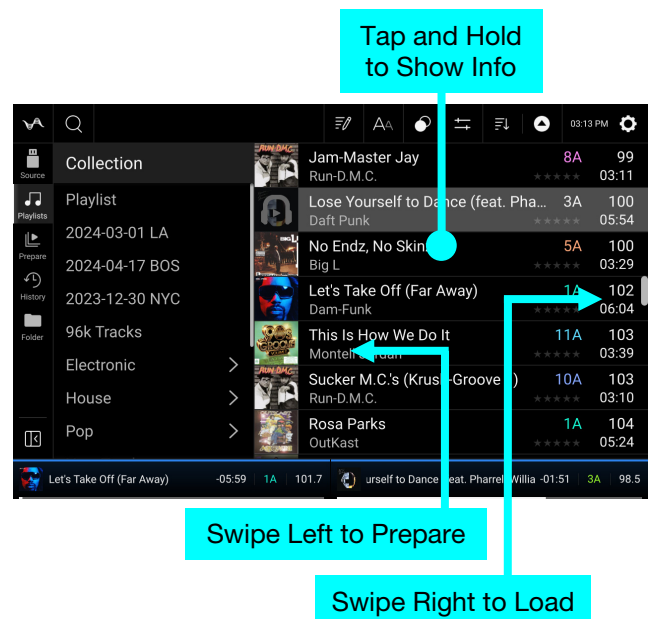

While viewing the Prepare list:

To load a track to the layer currently in focus on the deck, swipe the track to the right. Alternatively, press the **Select/Zoom** knob.

To load a track to a selected layer or sampler slot, partially-swipe the track to the right, or double-tap the track, then tap **Load** and select the layer or sampler slot.

To remove a track from the Prepare list, swipe the track to the left.

To remove all tracks from the Prepare list, tap the **Clear List** icon at the top of the display.

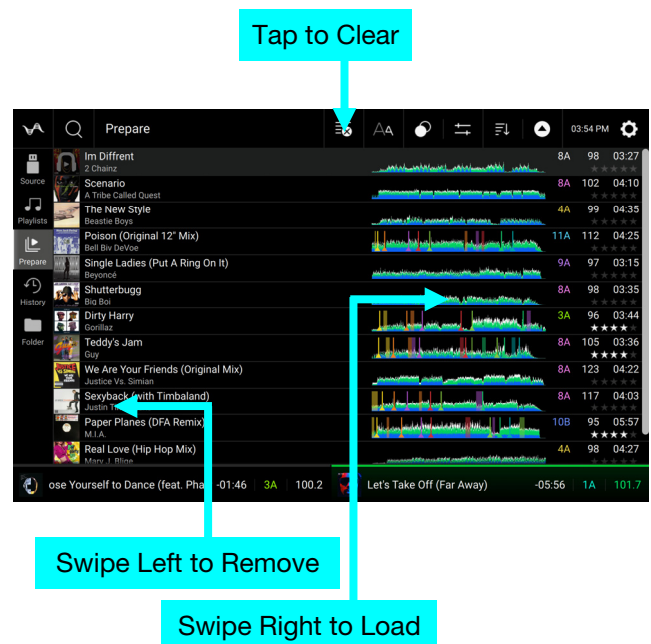

Searching & Filtering Tracks

To search, tap the **magnifying glass icon** and use the keyboard that appears in the display. The search results are based on the following criteria: title, artist, album, length, key, comment, BPM, genre, label, year, date added or filename. By default, only **Title** and **Artist** are selected. Tap the **magnifying glass icon** again and then use the dropdown menu to select other categories, or to **Search All** categories.

Note: To reduce search time, only select fields in which you wish to search.

When searching from a playlist, you can choose to search only in that playlist (tap the playlist name) or your entire collection (tap **All**)

To hide the keyboard, tap the **keyboard icon** in the lower-right corner of the virtual keyboard, or tap anywhere on the screen other than the keyboard or the Search field.

To clear your search term, tap the **X** icon. Tap **Cancel** to stop searching

To filter your tracks, tap **Genre**, **Artist**, **Album**, **BPM** or **Key**, and then tap one of the available options. Only tracks tagged with that genre, album, artist, key, or BPM will be shown. (By default, the key is notated using the Camelot system.) You can also use the **Search** field while tracks are filtered to refine your results, or filter tracks from a search result.

Note: You can also use the preferences to set whether you want to show tracks with the same key only or tracks with compatible keys as well as the “tolerance” of BPM filter (to include tracks with tempos within 1–15 BPM of the selection). See [Profile > Library](#) to learn more.

To sort the list of results, tap the **Sort By** icon in the upper-right corner, and then tap one of the available options. Tap the **arrow** icon next to this to toggle between ascending and descending order.

Tap to Search

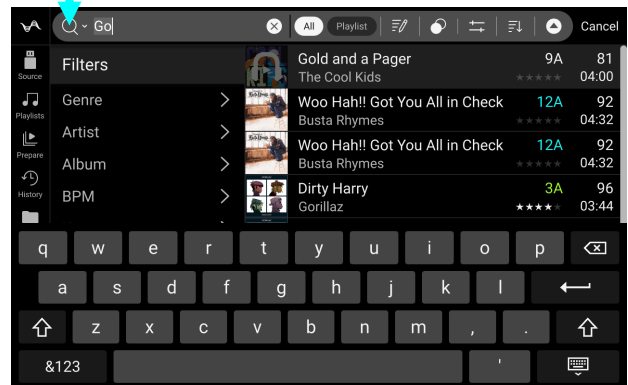

Tap to Select Search Criteria

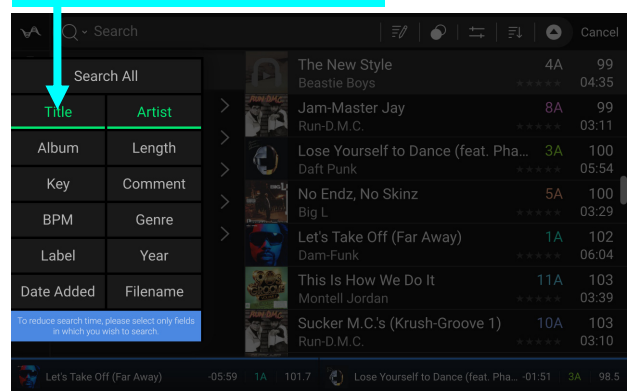

Tap to Toggle Ascending/Descending

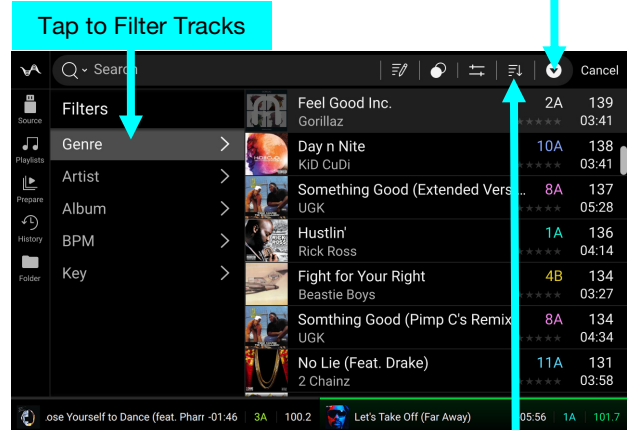

Tap to Choose Sort Preference

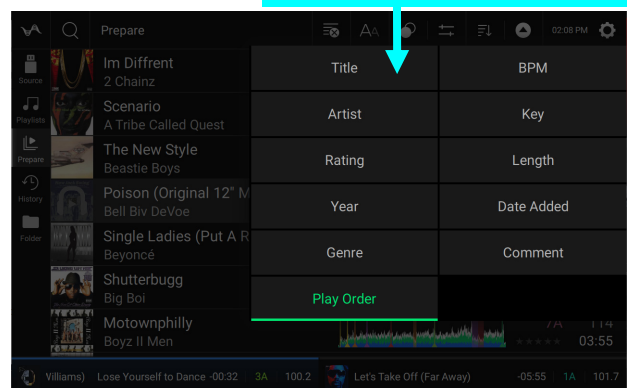

Match

In addition to the examples above, you can also use the **Match** tool to filter tracks that match the current lead track using a customizable set of parameters.

The Match function can be used in Playlist, Search, Prepare, and History views of the Browser. You can also access Match rules when viewing your Engine Remote Library.

Click the **sliders icon** to open the Match Rules screen, where you can select the following options for filtering tracks:

Follow Lead Deck: When enabled, tracks will be matched to the current Sync Lead deck. When disabled, use the following option to select the match deck.

Match to Deck: When Follow Lead Deck is disabled, use this option to select the deck for matching tracks.

BPM: Enable to match tracks by BPM. Use the - and + buttons to set the BPM range to match.

Key: Enable to match tracks by key. Select Fuzzy (includes relative keys of the dominant and subdominant keys of the lead track), Compatible (includes relative keys of the lead track), or Exact (includes only the same key of the lead track).

Genre: Enable to match track by genres. Select **Close** to include related genres (e.g., “Deep House” or “Acid House” will match to a track tagged with “House”), or **Exact** to match only the exact genre of the selected deck’s track.

Hide Played: When enabled, previously played tracks (highlighted in green text) will be hidden from the match results.

Note: Hide Played is unavailable when using Match in History view.

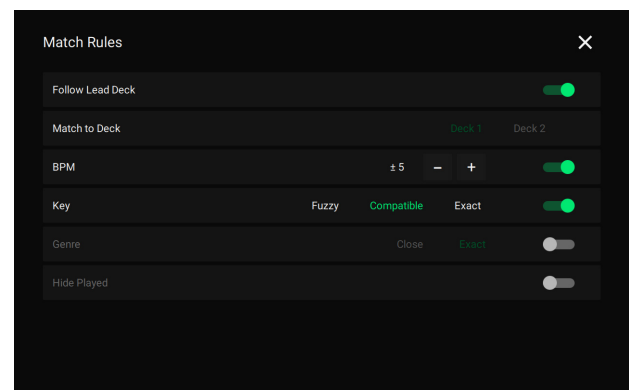
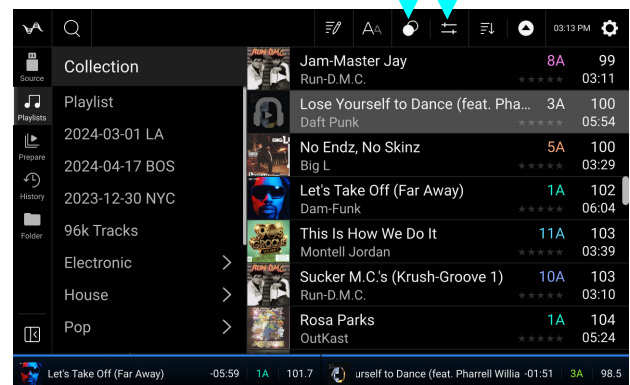

Once the Match Rules are set, tap the **match (circles) icon** to display the matching tracks in the list. If no tracks match the set rules, a message will appear in the track list noting that tracks may be hidden. Match results can be further sorted using the **Sort By** preferences and **Ascending/Descending** order.

Editing Playlists

Tap the **edit icon** at the top of the display while viewing the playlist screen. While editing is active, you can do any of the following:

To make a new playlist, tap **+ Create Playlist** in Playlist view.

To rename a playlist, swipe right on the playlist name. Use the keyboard that appears to type a new name, and then tap **Rename** to confirm. To exit without renaming, tap **Cancel**.

To add tracks to your playlist, tap a track to select it, and the open circle will become filled. After selecting tracks, tap and hold to move the tracks. You can drag the tracks over a playlist and release your finger to instantly add them.

To remove a track from your playlist, swipe left on the track name, and then tap **Remove From Playlist**.

To reorder tracks in a playlist, first make sure the **Sort Preference** is set to **Play Order**. Then, tap and hold on the track name (while editing mode is still active) and move your finger up or down to change the track order. You can also reorder playlists in the same way.

To remove a playlist, swipe left on the playlist name. A pop-up will appear for confirmation. Tap **Yes** to remove the playlist, or **No** to return to editing. Tracks in a removed playlist will remain in your collection.

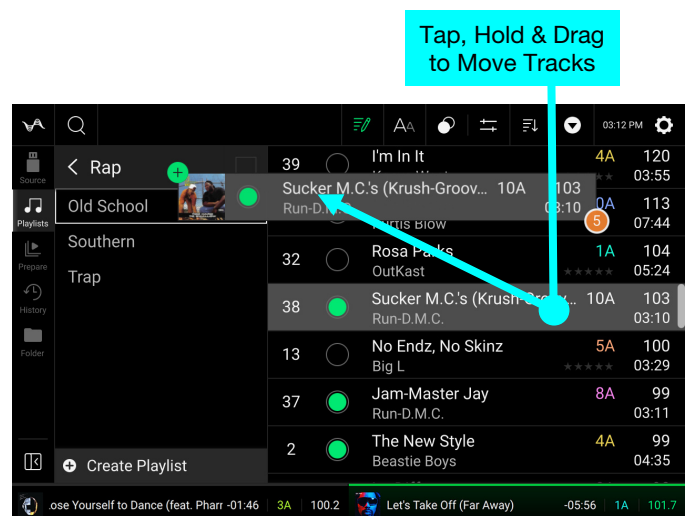
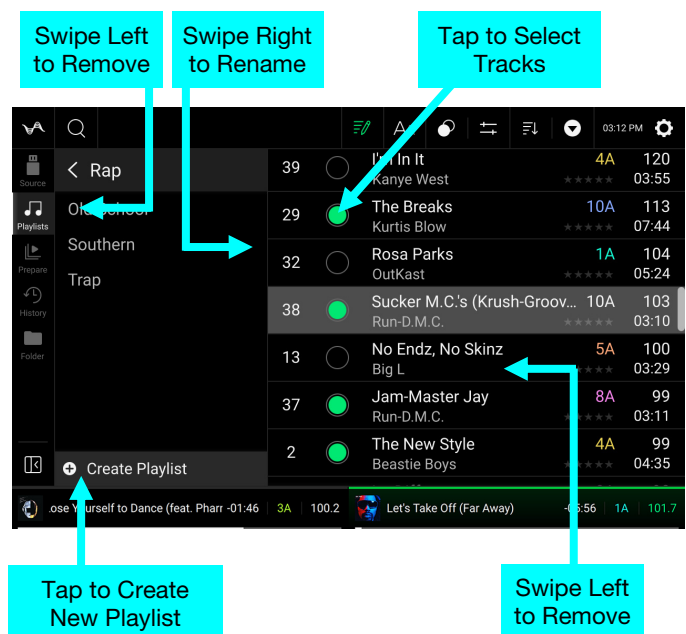
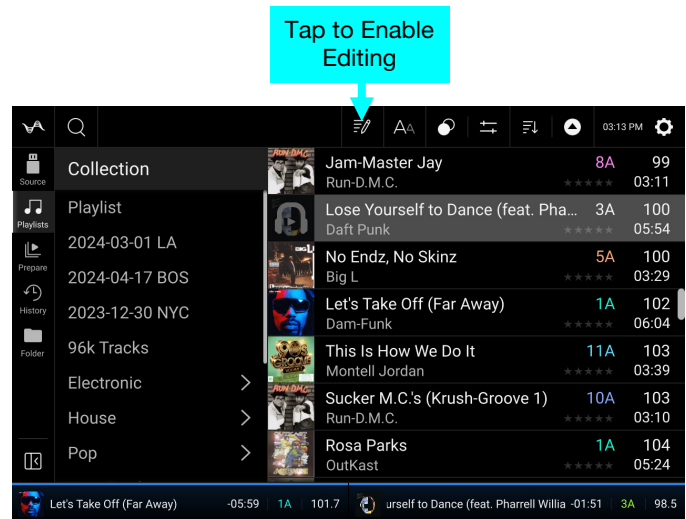

Playback & Cueing

To play or pause a track, press **Play/Pause** (▶/||).

To scratch a track, press **Vinyl** (SC5000 PRIME / SC6000 PRIME) or **Motor** (SC5000M PRIME / SC6000M PRIME) so it is lit brightly and then move the **platter**.

To set the initial cue point, press and hold **Shift** and press **Cue** at the desired location during playback.

To return to the initial cue point and stop, press **Cue**. The button will flash while the unit is paused at the cue point.

To return to the initial cue point and keep playing, press and hold **Shift** and press **Play/Pause** (▶/||).

To reverse playback, press and hold **Shift** and press **Censor/Reverse**. The button will flash while playback is reversed.

To return to normal playback, press **Censor/Reverse**.

To censor playback, press and hold **Censor**.

To return to normal playback, release **Censor**. Normal playback will resume from where it would have been if you had never engaged the Censor feature (i.e., as if the track had been playing forward the whole time).

To skip to the previous or next track, press one of the **Track Skip** ◀/▶ buttons.

To return to the beginning of a track, press **Track Skip** ◀ in the middle of a paused track.

To jump to a specific location in the track:

- If Needle Lock is **disabled**: tap the desired location in the track overview.
- If Needle Lock is **enabled**: pause playback and then tap the desired location in the track overview. Alternatively, make sure the **platter** is in Vinyl Mode (on SC6000 PRIME and SC5000 PRIME, press **Vinyl** so it is lit) or the **Motor** is on (on SC6000M PRIME and SC5000M PRIME, press **Motor** so it is lit), then stop the platter with your hand or palm and tap the desired location in the track overview.

See [Profile > Safety](#) to learn about Needle Lock.

To scan quickly through the track, press and hold **Shift** and then press one of the **Track Skip** buttons. If Needle Lock is enabled, pause playback before doing so.

To enable or disable Slip Mode, press **Slip**. In Slip Mode, you can jump to cue points, use the platters, or pause the track while the track's timeline continues (half of the waveform in the touchscreen will continue moving forward). When you stop whatever action you are performing, the track will resume normal playback from where it would have been if you had never done anything (i.e., as if the track had been playing forward the whole time).

To zoom in and out of the waveform, place two fingers on the display and spread them apart or pinch them together. Alternatively, turn the **Select/Zoom** knob.

Looping & Beat-Jumping

To create and activate an auto loop, press the **Auto Loop** knob.

To set the auto loop length, turn the **Auto Loop** knob to select the number of beats: **1/32, 1/16, 1/8, 1/4, 1/2, 1, 2, 4, 8, 16, 32, or 64**. The auto loop length in the layer info will change as the value is adjusted.

To create and activate a manual loop, press **Loop In** to set the start point, and then press **Loop Out** to set the end point. The loop will be activated immediately, and the loop will be indicated as a shaded area in the waveform and track overview.

To deactivate a loop, press the **Auto Loop** knob.

To move the loop, press and hold **Shift** and turn the **Auto Loop** knob while the loop is activated.

To double or halve the length of a loop, turn the **Auto Loop** knob while the loop is activated.

To manually edit the beginning or end of a loop, press **Loop In** or **Loop Out** respectively, then move the platter left or right to shorten or extend the loop region. Commit the edit by pressing **Loop In** or **Loop Out** again.

To beat-jump through a track, press one of the **Beat Jump** buttons. Each press will skip through the track by the set length. You can adjust the beat jump length by pressing and holding **Shift** and pressing either button. The beat jump length in the layer info will change as the value is adjusted.

You can also create and manage loops with the **Performance Pads** [Loop Modes](#).

Syncing & Pitch Adjustment

To **activate sync**, press **Sync**. The track tempo will turn green when sync is enabled. Tracks that are not synced will have their tempo displayed in white.

Note: Colors will appear differently when **Day Mode** is enabled in the **Control Center**.

To **set which deck is the primary “sync lead”**, or the deck that controls the sync BPM, **press Master**. Alternatively, tap the layer tempo on the touchscreen. The **sync indicator** (beat phase meter or beat keeper, described below) for the layer will show **“LEAD”** when set as the sync lead.

After Sync is activated and the sync lead is set, press **Sync** on any additional decks. The tempo of each deck will immediately synchronize to match the tempo of the sync lead deck.

The Sync behavior is determined by the **Sync Mode** setting in the **Profile > Playback** menu.

To **set a different PRIME hardware unit as the sync lead**, press **Master**. All connected units with Sync activated will use the tempo of this unit. You can also tap **Sync Lead** on the touchscreen to select which layer on the primary unit is used for sync.

To **deactivate sync**, press **Sync** again, or press and hold **Shift** and press **Sync**, depending on the setting of **Sync Button Action** in the **Profile > Playback** menu.

Sync Indicator option in the **Profile > Display** menu determines whether the **Beat Phase** meter or **Beat Keeper** is displayed in Performance View for visually syncing tracks.

When set to **Beat Phase**, the **phase meters** on each layer can be used to visually match the beat grid phase of your tracks in relation to the current Sync Lead layer.

When the beat grid phase of the current deck matches the Sync Lead layer, the meters will be centered and fully lit green. When the beat grid phase of the current deck is behind or ahead of the Sync Lead layer, the meter will be positioned to the left or right of the center, respectively. The phase meter visualizes a 1/2 beat in both directions. To manually match the tracks using the phase meter, nudge the current layer until both meters are centered.

When a track is paused or unanalyzed, the phase meter will show a grey line.

When set to **Beat Keeper**, the sync indicator shows the current beat value of the Sync Lead track in the top row, and the track on the current deck in the bottom row.

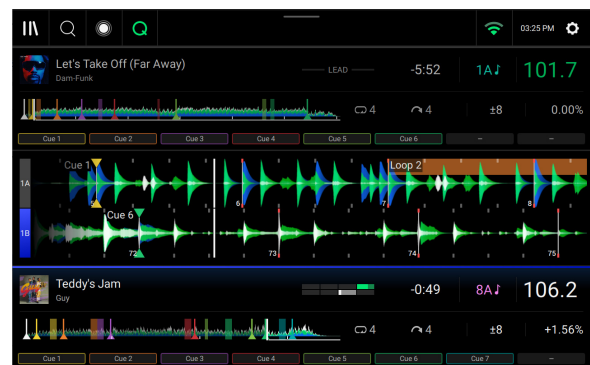

To **adjust the track’s pitch**, move the **pitch fader**. You can do this only when the deck is not synced.

Important: If Sync is activated, moving the pitch fader on the “primary” SC6000/SC6000M PRIME hardware unit will change the speed of all synced units, while moving the pitch fader on other units will do nothing.

When active layer’s **pitch fader** is moved while using dual layer playback, the **takeover arrows** on the inactive layer will light to indicate which direction to move the pitch fader in order to match the active layer’s pitch.

To **adjust the track’s pitch momentarily**, press and hold one of the **Pitch Bend –/+** buttons.

To **adjust the range of the pitch fader**, press and hold **Shift** and press one of the **Pitch Bend –/+** buttons to select **±4%, 8%, 10%, 20%, 50%, or 100%**.

To lock or unlock the track's key, press **Key Lock/Pitch Reset**. When Key Lock is activated, the track's key will remain the same even if you adjust its speed.

To sync the track's key to another playing track, press and hold the **Key Lock/Pitch Reset** button. The key value is dependent on the **Key Sync Mode** setting in the **Profile > Playback** menu.

To reset the track's pitch to 0% and lock the key, press **Key Lock/Pitch Reset**. To reset the track's pitch to 0% without locking the key, press and hold **Shift** and press **Key Lock/Pitch Reset**. The track's pitch will return to its original pitch (0%) regardless of the position of the pitch fader.

To change the key, tap the key in Performance View to open the Key Change Menu. In the Key Change Menu, you can access the following controls:

Tap the **musical note** to lock or unlock the track's key.

Tap the **Sync** button to enable Key Sync.

Tap the key values to decrease or increase the key. The key in the center will update to show the new key and the amount of change from the original key,

Tap the **reset** button to reset the key.

Tap the **X** button to close the Key Change Menu.



Beat Grid Editing

You can edit a track's beat grid directly from your PRIME hardware, the same way as you can when using the Engine DJ software.

To enable beat grid editing, open the **Control Center** and tap the **Beat Grid Edit** icon. Alternatively, press and hold the **Select/Zoom** knob for a second.

Note: Beat grid editing is not accessible if there are no tracks added to the decks or if the deck is in use with Bluetooth.

Important: When the **Cue/Loop Quantization** feature is **on**, hot cue points and loop points will be automatically aligned according to the degree of quantization. See [Profile > Cues/Loops](#) to learn about this.



To adjust the position of the beats:

- Tap the **Downbeat Left/Right** buttons to move the beats based on the current analyzed grid.
- Tap the **Shift Left/Right** buttons or nudge the hardware **platter** to "slip" the entire grid left or right.
- Tap the **Insert Anchor** button to move the closest beat to the position of the playhead. All other beats will also shift accordingly. This allows you to create flexible beat grids for tracks with fluctuating tempo.
- Tap the **Delete Anchor** button to delete the closest anchor within a few beats.

To adjust the tempo:

- Tap the **BPM** field to input a new tempo. Use the number pad that appears to input the new value, and then tap the **Enter** button to accept it. Tap the **X** icon to cancel changes and return to the grid edit controls.
- Tap in the **Tap Tempo** icon area to manually set a tempo based on repeated taps.
- Tap the **Decrease/Increase BPM** buttons to decrease and increase BPM in small increments.
- Tap the **2X** and **/2** buttons to double or halve the current BPM.

To reset the beats to the original analyzed tempo and grid, click the **Reset** button.

To lock the beat grid, click the lock icon. When locked, further editing is prevented and all other Grid Edit controls will be greyed out.

To select another track for editing, tap the **Track Information** area.

To exit beat grid editing, tap the **X** in the top-right corner of the touchscreen, or select another mode.

Pad Modes

The 8 pads have different functions in each pad mode.

To enter each pad mode, press the corresponding button: **Hot Cue**, **Loop**, **Roll**, or **Slicer**.

To enter Sampler Mode, press **Roll** twice.

To enter Stems Mode, press **Hot Cue** twice. A one-time license purchase is required to enable Stems Mode. See [Stems Mode](#) for more information.

Hot Cue Mode



In Hot Cue Mode, you can use each pad to jump to an assigned hot cue point. The location of set hot cue points and timing of triggered hot cue points will depend on the current **Quantize** setting, if enabled.

Tip: You can use the Engine DJ software to set, name, and assign colors to your hot cue points. The names and colors will appear in the display for reference.

To assign a hot cue to a pad, press a dimly lit pad at the desired location in the track. The pad will light up when a hot cue point is assigned.

To jump to a hot cue point, press the corresponding pad.

To clear a hot cue from a pad, press **Shift** and the desired pad. The pad will return to dimly lit when there is no hot cue point assigned to it.

Loop Modes

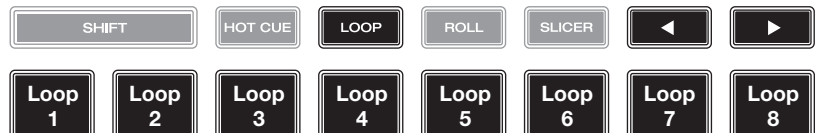

In Manual Loop Mode (first press), you can use each pad to activate an assigned loop. Pressing Loop for the first time will always enter Manual Loop Mode.

Tip: You can use the Engine DJ software to set and name your loops. The names will appear in the display for reference.

To assign a loop to a pad and enable it, press a dimly lit pad to create a Loop In point at the current location, and then press it again to create the Loop Out point at another location. You can also assign an auto loop to a pad by pressing a dimly lit pad while in the auto loop. The loop will activate immediately, and the pad will light up.

To enable a loop, press the corresponding pad. Once a loop has been created, you can retrigger it by pressing the corresponding pad again, depending on the **Saved Loop Behavior** setting in the [Profile > Cues/Loops](#) menu.

To enable an active loop, press and hold the **Parameter** ◀ button and press a pad with a saved loop. Active loops will begin looping automatically as soon as they are reached, and are shown with a striped pattern in the track waveform. You can also set these in the Engine DJ software.

To delete a loop, press **Shift** and the desired pad.

In Auto Loop Mode (second press), you can use each pad to create and activate an auto loop. Pressing Loop while in Manual Loop Mode will enter Auto Loop Mode.

To activate an auto loop, press a pad. The display will show the length of the auto loop for each pad.

To deactivate an auto loop, press the pad again.

Roll Mode

(T denotes a triplet-based time division)



In Roll Mode, you can press and hold each pad to trigger a “loop roll” of a certain length while the track’s timeline continues (half of the waveform in the display will continue moving forward). When you release the pad, the track will resume normal playback from where it would have been if you had never done anything (i.e., as if the track had been playing forward the whole time).

To trigger a roll, press the corresponding pad. Pads with triplet-based loop rolls are lit purple.

Slicer Mode



In Slicer Mode (first press), the eight pads represent eight sequential beats—“slices”—in the beat grid. The currently playing slice is represented by the currently lit pad; the light will “move through the pads” as it progresses through the eight-slice phrase. You can press a pad to play that slice. When you release the pad, the track will resume normal playback from where it would have been if you had never pressed it (i.e., as if the track had been playing forward the whole time).

To play a slice, press the corresponding pad. Use the **parameter buttons** to change the length of the repeats.

In Slicer Loop Mode (second press), the eight pads represent eight sequential beats—“slices”—in the beat grid. The currently playing slice is represented by the currently lit pad; the light will “move through the pads” as it progresses through the eight-slice phrase, which will loop (this is the difference between this mode and Slicer Mode). You can press a pad to play that slice. When you release the pad, the track will resume normal playback from where it would have been in the loop if you had never pressed it (i.e., as if the track had been playing forward the whole time).

Sampler Mode

In addition to the Pad Modes above, PRIME hardware also includes a Sampler Mode. This can be accessed from your hardware by pressing **Roll** twice. You can assign and trigger up to eight samples using your performance pads.

You can view your assigned samples in Performance View by enabling the Performance Pads option in the [Layout](#) menu. When the Sampler pad mode is selected, you will see the sample names loaded to each pad in the sampler slots in Performance View.

Your hardware includes a set of pre-installed sample content, which you can browse from **Library View** when **Sampler Content** is selected as a source.

To load a sample from Library View, half-swipe the sample to the right and then tap **Load**. Next, instead of selecting a deck, tap one of the eight sampler slots on the touchscreen. Alternatively, press the hardware pad where you want the sample assigned. If a sample is already loaded to the selected pad, the new sample will replace the existing sample.

Loaded samples will be retained in memory across device reboots if the same source drive is connected and selected.

To trigger a sample, press the performance pad on the hardware.

The sampler volume can be adjusted using the **Sampler Volume** slider in the [Control Center](#).

Sampler audio routing can be adjusted using the **Sampler Output** option in the [Settings > Mixer](#) menu.

To stop a playing sample, hold **Shift** and press the performance pad.

To remove a sample, you must first exit Performance View. Samples cannot be removed while in Performance View to prevent accidental ejection. While in Library View, Settings, or another page, press and hold **Shift** and then press the performance pad with the sample you want to remove. If the sample is playing, you will need to stop it first, and then remove it.

Stems Mode

Your PRIME hardware also supports Stems pad mode. To enable this, you must first activate Stems by purchasing a one-time license to add to your Engine DJ profile.

1. Visit enginedj.com/stems to purchase a one-time license to add to your Engine DJ profile.
2. Once you have purchased the Stems license, power on your PRIME hardware and make sure you are connected to Wi-Fi and signed into your Engine DJ profile.
3. A pop-up will appear notifying you that new features are available, and you will need to reboot your unit to activate them. Tap **Reboot** to restart your unit, or tap **Ignore** to temporarily dismiss this message.
4. Once your unit has restarted, stems functionality will be available on your unit.

Track stems must be created using the Engine DJ software and packed to an external drive for use with PRIME hardware.

Tracks with stems will show a **Stems icon** before the track name. All stemmed tracks can be found in the **Stems** list of Library view when it is enabled in the [Profile > Library](#) menu (on by default when Stems is activated).

Adding a stem track to a deck will allow you to use Stems pad mode. This can be accessed from the hardware by pressing the **Hot Cue** button twice when a stem-enabled track is added to a layer.

When Stems Pad Mode is enabled, the top four pads can be used to isolate stems. From left to right, these pads control **Vocal**, **Melody**, **Bass**, and **Drums**.

To mute a stem, press the pad so it is dimly lit.

To unmute a stem, press the pad again so it is brightly lit.

Use the **parameter buttons** (◀/▶) to quickly isolate **Acapella** or **Instrumental** stems. Press ◀ to mute the **Melody**, **Bass**, and **Drums** stems and isolate the **Vocal** stem. Press ▶ to mute the **Vocal** and isolate the **Melody**, **Bass**, and **Drums** stems. Press ◀/▶ again to unmute.

Touch FX

The Touch FX feature allows you to control ten powerful audio effects via the touchscreen to create buildups, drops, and transitions with a single touch.

To access Touch FX, tap the **Touch FX** icon in the toolbar at the top of the screen.

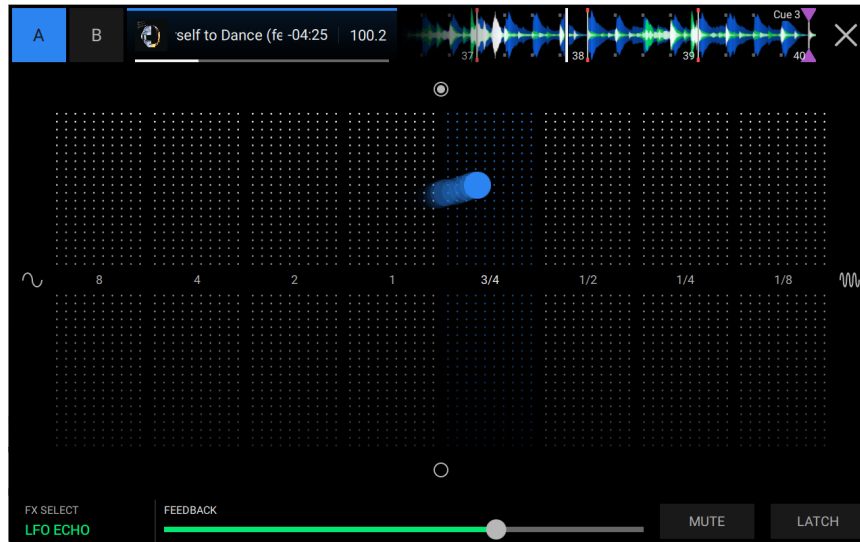

Touch FX can be applied to a single layer at a time. Tap the layer letter in the upper-left corner of the screen to select the desired layer. The track name, time, BPM, and waveform overview will be shown.

Each effect has a pair of parameters, one mapped up and down and one mapped left and right, that can be continuously adjusted by tapping and dragging your finger around the center area. See [Appendix > FX Parameters > Touch FX](#) for more information on the available Touch FX parameters.

To change the current effect, use the **FX Select** menu in the bottom-left corner of the screen to select from the following options:

- LFO Echo
- Filter Roll
- Filter Echo
- Filter Dub Echo
- Filter Gate
- Noise Gate
- Filter Reverb
- Flanger
- LFO Filter
- Filter

To adjust an additional effect parameter, such as a **Feedback** or **Resonance** control, use the slider at the bottom of the screen.

To mute the incoming signal, tap the **Mute** button at the bottom-right of the screen. This function emulates pulling a mixer fader down to zero while continuing the effect-processed audio.

To hold the current position of the Touch FX, tap the **Latch** button at the bottom-right of the screen. The effect will remain on in any position you move it to until Latch is turned off. Latch will automatically turn off if you switch active layers or change FX selection while it is enabled.

To close Touch FX and return to the previous screen, tap the **X** icon in the upper-right corner of the screen. Alternatively, press **View**, **Back**, or **FWD** to switch to another screen. If you navigate away from the Touch FX screen with **Latch** engaged, the Touch FX icon in the Toolbar will pulse to indicate it is still active.

Control Center

Press the **Shortcuts** button, **swipe down from the toolbar**, or **tap the gear icon** to open the Control Center. Here, you can quickly adjust commonly used **Parameters** using the widgets in the center of the screen. You can also access the following pages. Click the links below to jump to that part of the guide:

- **Layout** – This screen is used to adjust the appearance of Engine OS.
- **Profile** – This menu is used to edit your performance preferences.
- **Settings** – This menu is used to edit the settings of the PRIME hardware.
- **Source** – This menu is used for selecting your source media device.
- **Wi-Fi** – This menu is used for connecting to and configuring your Wi-Fi network.
- **Bluetooth**® – This screen is used for linking to and configuring Bluetooth devices.
- **Engine Lighting** – This menu is used for working with the SoundSwitch Engine Lighting integration.

Tap the **X** in the upper-right corner of the screen to exit the Control Center. Alternatively, press **Back** or **FWD**, or swipe up from the bottom of the screen.

Parameters

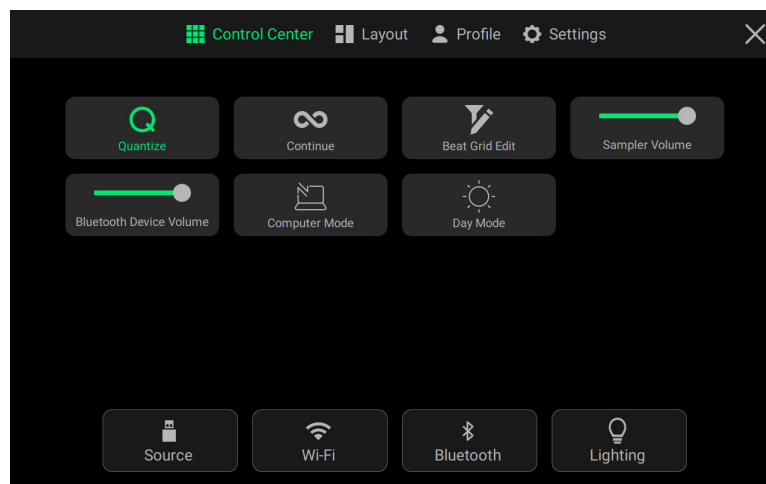

Quantize: Tap this to enable or disable quantization. When enabled, time-based features like triggering cues and loops will snap to the beat-grid according to the **Cue/Loop Quantization** setting in the **Profile > Cues/Loops** menu.

Continue: Tap this to enable or disable continuous playback, which will keep playing the next track when the active track has ended.

Beat Grid Edit: Tap this to access beat grid editing from the touchscreen. See **Beat Grid Editing** for more information.

Sampler Volume: Use this slider to adjust the sampler volume level. See **Sampler Mode** for more information.

Bluetooth Device Volume: Use this slider to adjust the Bluetooth device audio input level.

Computer Mode: Tap this to switch your PRIME hardware to computer mode. In computer mode, you can use your Engine OS hardware to send and receive MIDI messages to and from your computer.

Day Mode: Tap this to enable or disable Day Mode. This mode inverts the colors of the Engine OS interface for better visibility in bright daylight environments.

Layout

Use the **View 1-3** buttons to select a saved layout preset, and then use the options below to configure it. You can cycle between these options by pressing and holding **Shift** and pressing the **View** button on your PRIME hardware.

Press the **Reset Current View** button to reset the selected layout preset to its default configuration.

Performance Layout

- Deck Layout:** Use this option to determine the layout of the decks in Performance View. Select **Single** to show only one layer, **Dual (Stacked)** to show both layers, with Layer A performance controls on top and Layer B performance controls on the bottom, or **Dual (Grouped)**, with both Layers' performance controls on top.

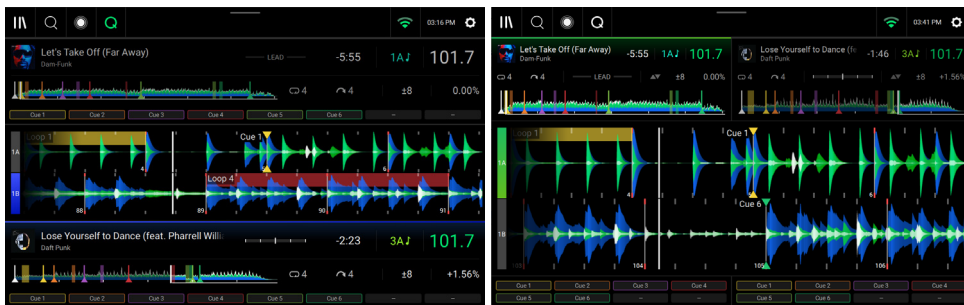

- Waveform Orientation:** Use this option to select whether the track waveforms are in **Horizontal** or **Vertical** display in Performance View.



- Performance Pads:** Tap this to enable or disable the performance pads from appearing in Performance View. When enabled, the pads will be shown under the track overview on the touchscreen (see below).

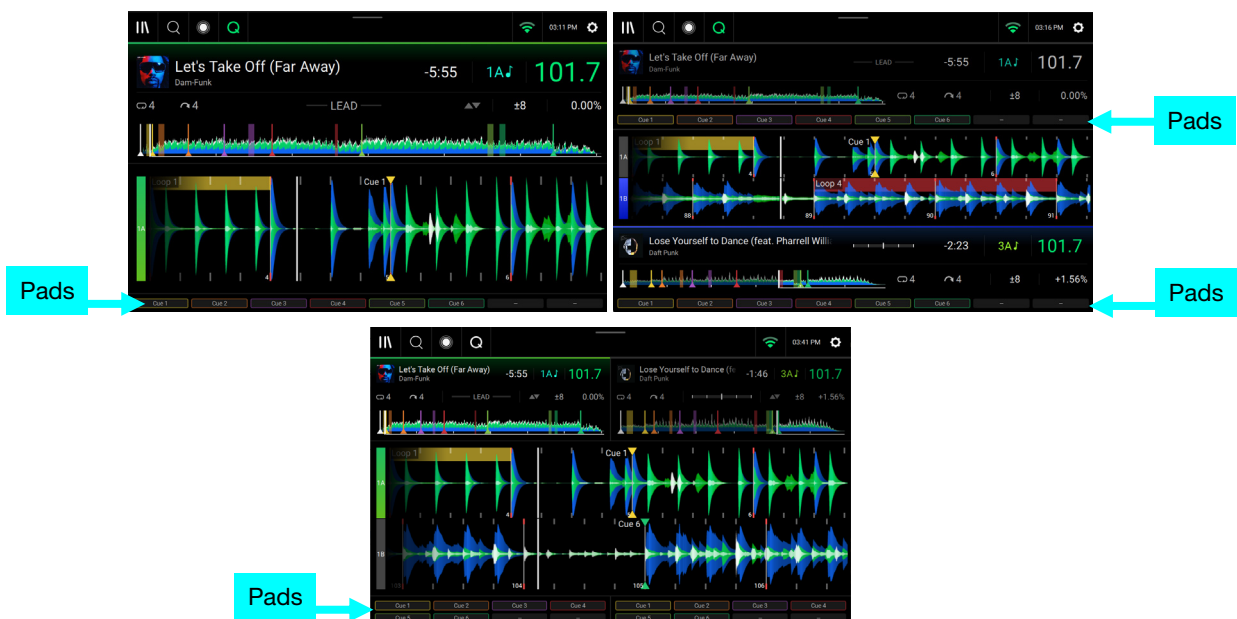

- **Performance Library:** Tap this to enable or disable the Performance Library from appearing in Performance View. The location of the Performance Library will depend on the waveform orientation and the number of layers and waveforms displayed.



Deck Behavior

- **Layer B:** This determines whether this PRIME hardware displays the Layer B controls (**On**) or not (**Off**).
Note: When the Layer B deck controls are hidden, you can still use the layer to route preview, sampler, or Bluetooth audio, and apply Touch FX to it.
- **Deck Swap:** Use this option to switch the position of the layer in relation to the **A/B Outputs**. When set to **Regular**, Layer A will output to the **A Output**. When set to **Swapped**, Layer A will output to the **B Output**. This can also be used to match your layout to the position of a connected LC6000 PRIME controller.

Profile

To open the **Profile** menu, press the **Shortcuts** button, or swipe down from the toolbar, and then tap the **Profile** tab.

To close the **Profile** menu, press **View**, swipe up, or tap the **X** button.

In the **Profile** menu, swipe up or down to scroll through the options, and tap an option to select it.

Press the **Log In** button to log into your Engine DJ profile. Once you are logged in, you can access crowd-sourced streaming metadata and beat grid information, and automatically connect to associated streaming and cloud services. Existing streaming and cloud service logins will be removed, and any tracks loaded to a deck will be ejected. To manage your connected services, visit enginedj.com and log into your account.

Press the **Save To My Drive** button to save your settings to a connected drive. Profiles can be loaded when a media device with an Engine DJ profile is connected to your PRIME hardware.

Playback

- **Motorized Platter Start (SC6000M PRIME only):** This setting will determine how quickly your track starts to play. When set to **Normal**, the track will play in relation to the motor start-up speed. When set to **Instant**, the song will begin playing immediately, and the motor and platter will catch up to the song within a few milliseconds.
- **Track Start Position:** This setting determines where the beginning of a track is after it loads. Select the actual start of the file (**Track Start**) or the automatically detected beginning of an audio signal (**Cue Position**).
- **Maintain Play State on Load:** When enabled, loading a new track will automatically enter the play state of the previous track on the deck where it was loaded. For example, if a track was already playing, the new track will begin playing as soon as it loads. When disabled, tracks will always load with playback paused.
- **Default Speed Range:** This setting determines the range of the **pitch fader**. Select **±4%**, **8%**, **10%**, **20%**, or **50%**.
- **Nudge Sensitivity (SC6000 PRIME only):** This determines the level of sensitivity when moving the platters: **Min**, **Low**, **Mid**, **High**, or **Max**.
- **Sync Mode:** This setting determines the degree of synchronization applied when you press the Sync button on your PRIME hardware:
 - **Bar:** The tempo will be synced, and the track will be automatically bar-matched with the track on the sync lead deck (the downbeats of each bar will be aligned).
 - **Beat:** The tempo will be synced, and the track will automatically beat-matched with the track on the sync lead deck.
 - **Tempo:** Only the tempo will be synced (the BPM will match that of the sync lead deck).
- **Sync Button Action:** This setting determines how the **Sync** button will act when pressed.
 - **Toggle:** This mode allows you to toggle sync on and off without having to hold **Shift**.
 - **Shift Disable:** This mode requires **Shift** to be held in order to turn off sync.
- **Pitch Control Type:** This setting determines the primary function of the Pitch Bend buttons. Select **Pitch Bend** to keep the primary function as momentarily reducing or increasing the pitch, or select **Range** to set the primary function to adjusting the range of the pitch fader. The function not used as the primary will still be available by holding **Shift** and using the **Pitch Bend** buttons.
- **Pitch Bend Behavior:** This setting determines the behavior of the **Pitch Bend** button function. When set to **Fixed**, pressing and holding the **Pitch Bend** buttons changes the speed of the track at a consistent rate. When set to **Progressive**, the longer the **Pitch Bend** buttons are held, the greater the rate of speed change.
- **Key Sync Mode:** This setting determines whether key syncing is **Strict** or **Fuzzy** (default). When set to **Strict**, tracks will only be key synced to the same or relative key (i.e., 7a to 7b). When set to **Fuzzy**, the available compatible keys are increased to include relative keys of the dominant and subdominant keys of the lead track, decreasing the amount of pitch shifting necessary to match two tracks together.

Cues/Loops

- **Cue/Loop Quantization:** This setting determines the degree of quantization for time-based features: hot cue points, loops, and loop rolls. Select **1/8 beat**, **1/4 beat**, **1/2 beat**, **1 beat**, or **4 beats**.
- **Paused Hot Cue Behavior:** This setting determines how pads will play their hot cue points. When set to **Momentary**, playback will start from a hot cue point when you press and hold its pad—release the pad to return to the hot cue point. When set to **Trigger**, playback will start from a hot cue point (and continue) when you press and release its pad.
- **Default Loop Size:** This setting determines the default size of an auto loop when you load a new track to the deck: **None**, **1**, **2**, **4**, **8**, **16**, or **32** beats.
- **Default Beat Jump Size:** This setting determines the default size of the beat jump when you load a new track to the deck: **None**, **1**, **2**, **4**, **8**, **16**, or **32** beats.
- **Link Beat Jump / Loop Size Controls:** This setting determines whether the default loop size and beat jump size are always linked to the same value or not. Select **On** or **Off**.
- **Smart Loops:** This setting determines whether or not a manual loop will be automatically expanded or reduced to a conventional length (e.g., 2 beats, 4 beats, 8 beats, etc.) when you set it. Select **On** or **Off**. This setting works independently of the quantization setting.
- **Move Cue To Loop In:** This setting determines whether the song's initial **Cue Point** will automatically be moved to the start of a loop (**On**), or remain at its current point (**Off**).
- **Saved Loop Behavior:** This setting determines the action of loops after they have been saved. When set to **Reloop**, pressing a pad with a saved loop will start playing the loop again. When set to **Disable**, pressing a pad with a saved loop will turn off the loop.
- **Paused Saved Loop Behavior:** This setting determines the action of saved loops that are paused. When set to **Trigger**, pressing a pad with a saved loop on a paused track will trigger track playback from the point of the active loop. When set to **Enable**, pressing a pad with a saved loop on a paused track will move the playhead to the start of the loop, but the track will remain paused.

Display

- **Reset Played Tracks:** Click **Reset** to reset the played status of all tracks.
- **Track Title:** This setting determines whether tracks titles are shown as the track's **Filename** or its embedded **Metadata** (tags).
- **Time Format:** This setting determines whether or not pitch adjustment affects how the track time is displayed. When set to **Static**, the track's time corresponds to locations in the track as usual; adjusting the pitch does not affect it. When set to **Dynamic**, the track's time will automatically adjust to account for changes in pitch. For instance, if you set the pitch fader to **-8%**, the track time will increase so it is 8% longer.
- **Track End Warning:** This setting determines how long before the end of a track PRIME hardware will warn you that it is nearing the end. If the track is on the currently selected layer, the **platter ring** and **track overview** will flash. If the track is on the opposite layer, the **Layer** button will flash.
- **On Air Mode:** This setting changes the platter ring illumination when the channel fader on the Denon DJ mixer is up or down, indicating an active or "on air" deck. When this setting is **On**, raising the channel fader will change the platter color from **white** to the selected color. When this setting is **Off**, the user-selected color will always be shown regardless of the channel fader position.

Note: This requires a connection to a compatible Denon DJ mixer via Ethernet.

- **Sync Indicator:** This setting determines whether the **Beat Phase** indicator or **Beat Keeper** indicator is active in Performance View.
- **Waveform Style:** This setting determines the appearance of track waveforms. Select **Tri-Band** for Engine OS waveforms where blue represents bass, green is mid-range, and white is treble. Select **RGB** for software-style waveforms where red represents bass, green is mid-range, and blue is treble.

Note: RGB waveforms and track overviews will be built when loading a track to a deck. Alternatively, you can use Engine DJ software to **Analyze: Get missing analysis data** and reimport your tracks with RGB waveforms.

Safety

- **Lock Playing Deck:** This setting determines whether or not you will be able to load a track to the deck as it is playing. Select **On** or **Off**. When this setting is on, the deck must be paused in order to load a track to it.
- **Needle Lock:** This setting determines whether or not you can tap the **track overview** in the display to jump to that location in the track during playback. Select **On** or **Off**. You can use the track overview while playback is stopped regardless of this setting. Alternatively, make sure the platter is in Vinyl Mode (press Vinyl so it is lit), touch the top of the platter, and tap the desired location in the track overview.
- **Pad Lock:** This setting determines whether the pads and pad mode buttons (**Hot Cue**, **Loop**, **Roll**, **Slicer**) are enabled or disabled. Select **On** or **Off**.

Library

- **Stems List:** Use this option to enable or disable the **Stems** list from appearing in Library view.
Note: Stems support requires a one-time license purchase and activation. See [Stems Mode](#) for more information.
- **Key Notation:** This setting determines how the track key is notated in the display. You can view the key as all **Sharps**, all **Flats**, **Open Key**, or **Camelot**.
- **Key Filter:** This setting determines whether the **Key** filter shows tracks with the same key only (**Match**) or tracks with compatible keys (**Compatible**).
- **BPM Range:** This setting determines the lowest- and highest-possible BPM values that will be used when tracks are analyzed: **58–115**, **68–135**, **78–155**, **88–175** or **98–195** BPM.
- **BPM Filter Tolerance:** This setting determines the “tolerance” of the **BPM** filter so you can include tracks with tempos that are within a small range of the selected tempo. Select **±0**, **1**, **2**, **3**, **5**, **10**, or **15**.
- **Collection Browse Behavior:** This setting determines browsing behavior when using the Library. When set to **Select**, tapping a playlist or folder will select it, and a double-tap is required to open it. When set to **Open**, tapping a playlist or folder will open it.

Deck Colors

- **Deck Colors:** These settings determine the layer color, including the color of the light ring around the platter for each layer on each player. Tap the arrow next to **A** or **B** to select the layer, and then tap a color to select it. The light ring will change color immediately.

Settings

To open the **Settings** menu, press the **Shortcuts** button, or swipe down from the toolbar, and then tap the **Settings** tab.

To close the **Settings** menu, press **View**, swipe up, or tap the **X** button.

In the **Settings** menu, swipe up or down to scroll through the options, and tap an option to select it:

Device

- **Player #:** This setting determines the number of this player. When selecting a source device to browse, this number is shown next to the device name in the display.

Note: This number will be automatically assigned when in a network with a Denon DJ X1800/X1850 PRIME mixer. You can manually override the assigned number by changing this setting.

- **Wi-Fi:** This determines whether Wi-Fi connectivity is enabled (**On**) or disabled (**Off**). Tap the **gear icon** to open the Wi-Fi settings. See [Wi-Fi](#) for more information about the Wi-Fi menu.
- **Bluetooth:** This determines whether Bluetooth connectivity is enabled (**On**) or disabled (**Off**). Tap the **gear icon** to open the Bluetooth settings. See [Bluetooth](#)® for more information about the Bluetooth menu.
- **Time/Date:** This displays the current time and date. Tap **Sync Time** when connected to the internet to automatically sync the time.
- **24 Hour Clock:** This setting determines whether the **Time** uses the 12 Hour Clock (**Off**) or 24 Hour Clock (**On**).
- **Time Zone:** Displays the current time zone, formatted as **Region / City**.
- **Set time zone manually:** Enable this setting and then tap the **gear icon** to manually set your local time zone.
- **Playhead Position:** Use this slider to set the position of the playhead along the track waveform in Performance View.
- **Hide Title/Artist:** Use this setting to enable “trainspotting mode,” which hides the Track Title and Artist from decks.
- **Track Preview:** When active, Track Preview will reveal a play button for each song in the library, allowing the songs to be auditioned in the cue without loading a song to the deck. Select **On** or **Off**. When **On**, track preview audio will be routed to the active layer when no tracks are loaded. When tracks are loaded, the preview audio will be routed to the inactive layer.
- **Screen Brightness:** This setting determines the brightness of the touchscreen: **Low**, **Mid**, **High**, or **Max**.
- **Screen Saver Time:** This determines if and when the screen saver will turn on after no activity for the selected time: **Off**, **15 mins**, **30 mins**, **60 mins**. While the screen saver is active, the touchscreen display will dim. Interact with the screen or any hardware control to exit the screen saver.
- **Encoder Behavior:** This setting determines the default behavior when turning the **Select/Zoom** knob while in Performance View. When set to **Open Library**, turning the **Select/Zoom** knob will open Library View. When set to **Waveform Zoom**, turning the **Select/Zoom** knob will adjust the zoom level of the waveforms in Performance View.

Mixer

- **Sampler Output:** This setting determines where Sampler audio is routed: **Layer A** or **Layer B**.

FX

General Settings

- **Effect Select Behavior:** When set to **Default**, all effects settings will return to their default settings when a new track is loaded. When set to **Recall**, effects settings will be retained.

Services

- **Engine Lighting:** This determines whether SoundSwitch Engine Lighting is enabled (**On**) or disabled (**Off**). Tap the **gear icon** to open the lighting control interface.
- **Sync:** This determines whether Ableton Link is enabled (**On**) or disabled (**Off**). Ableton Link synchronizes beat, phase, and tempo of Ableton Live and Ableton Link-enabled applications over a wireless or wired network. All Link-enabled devices must be connected to the same local network.
Use the **Ableton Link Offset** slider to compensate for phase effects. You can adjust the offset between -200 and 200 ms.
- **Streaming:** Use these options to enable or disable connections to streaming service partners. When set to **On**, the selected service will be available in the **Source** menu.
- **Cloud:** Use this option to retrieve your Engine library database from a cloud storage service. You must first use the Engine DJ software to back up your database. Then, when this option is set to **On**, the selected service will be available in the **Source** menu, and you can access these files over an established internet connection.

Note: We recommend using only high-quality, name brand USB 3.0 or Class U1 or U3 SD cards as source drives, especially when cloud services are enabled.

About / Update

This page displays the product name, current firmware version, and other device information.

- **Firmware Update Mode:** If you are not running the latest firmware, tap **Options** to restart the PRIME hardware in Update Mode, which enables you to update its firmware. Follow the firmware update instructions included with the firmware update package you downloaded.
- **Send Anonymous Usage Statistics:** This determines whether or not your usage statistics will be sent occasionally to us, enabling us to improve the PRIME experience.
- **Legal:** Tap here to view the inMusic Brands EULA and patent list.
- **Factory Reset:** Tap here to restore the default factory settings for your device.

Source

The Source menu allows you to select a connected media device, streaming service, or cloud service for use with your PRIME hardware.

When the Source menu is open, all connected media sources are shown in the top part of the display. New sources that are available to connect to are shown at the bottom of the display.

To select a drive as a media source, tap the device name. The currently selected source device, if any, will be outlined.

To select a streaming or cloud service as your source, tap the streaming or cloud service name. If you have not set up a connection to the service yet, you will be prompted to sign in with your username and password or given a web link and code in order to activate your device. Once signed in or activated, you can use the streaming or cloud service to browse and add tracks. Streaming and cloud services may be enabled or disabled in the [Settings > Services](#) menu.

To open Wi-Fi connection menu, tap the **Wi-Fi icon** at the top of the display.

To eject a drive source, tap the eject icon next to the drive name. If a track from the selected source is currently in use, an alert will appear to note that the tracks will be unloaded. Tap **Eject Anyway** to continue or tap **Cancel** to return to the Source menu.

To exit the Source menu, tap the **X** at the top-right of the display. Alternatively, press the **View** button.

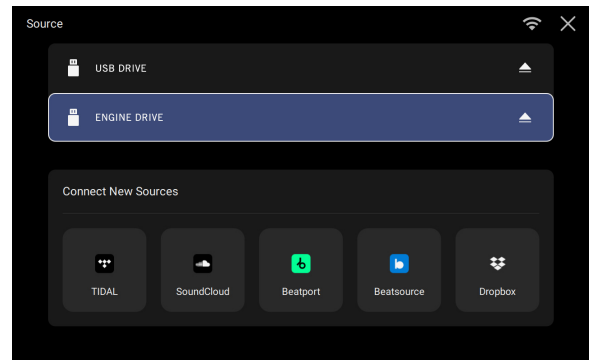

Engine Remote Library

In addition to connected devices, streaming services, and cloud services, you can also connect to an instance of the Engine DJ software running on a computer sharing the same network as your PRIME hardware. This allows you to browse and load tracks from your complete library without having to pack files to a portable drive.

To access your Engine Remote Library:

1. First, make sure your hardware and your computer are on the same network, and the Engine DJ software is opened. This can be done by connecting to the same Wi-Fi network, or by connecting directly using an Ethernet cable.
2. Tap the **Source** icon in Library View from your hardware, and locate your computer under the **Engine DJ Desktop** section.
3. Tap to select the computer, and your hardware will show **“Waiting for confirmation”** while another message appears in the Engine DJ software asking to accept or deny access to your hardware. Click **Accept** to approve and continue.

If the connection process is canceled, or if the connection is lost, both libraries will return to their previous selections.

4. Once the connection is established, you will be able to browse and load tracks from your Engine DJ software collection directly from your hardware.
5. When you load a track from the Engine Remote Library, the track will begin downloading over the network. The download progress will be shown on your hardware touchscreen. If the download fails, a **“Failed to Download”** message will appear on your hardware. You can remotely load tracks up to 250 mb in size.

Tracks will download with any performance data associated with the file in your Engine DJ software collection. This includes beat grids, saved cues, and saved loops. If no beat grid information is included with the downloaded track, your PRIME hardware will analyze the file once it is loaded.

Any edits made to performance data or track metadata from your PRIME hardware will be pushed back to your Engine DJ software collection, and vice versa.

Wi-Fi

The Wi-Fi menu allows you to connect to a local internet network so you can browse connected streaming and cloud services.

To enable Wi-Fi, tap the **Wi-Fi switch** at the top of the page. Once enabled, a list of local networks will appear on the display.

To establish a connection, tap the desired network name. If a password is required, you will be prompted to enter it. Once a connection is established, **Connected** will appear next to the network name.

To view information about the network, tap the **three-dots icon** next to the network name. **Tap Close** or anywhere outside the menu to close the Wi-Fi information menu.

A Wi-Fi connection menu will also appear when your PRIME hardware is powered on. On this page:

To enable Wi-Fi, tap the **Wi-Fi switch** at the top of the touchscreen.

To establish a connection, tap the desired network name. If a password is required, you will be prompted to enter it. Once a connection is established, the page will be dismissed.

To view information about the network, tap the three-dots icon next to the network name.

To dismiss this page, tap **Next** at the top of the touchscreen.

To prevent this page from appearing each time your hardware is powered on, tap the **Do not show again at startup** box so it is checked.

Bluetooth®

The Bluetooth page allows you to connect to a Bluetooth audio input for streaming, or a Bluetooth keyboard for searching tracks.

To enable Bluetooth, tap the **Bluetooth switch** at the top of the page. Once enabled, a list of devices will appear on the display. You can also enable Bluetooth from the Device menu in the [Settings > Device](#).

To link to an available device:

1. First, make sure your Bluetooth device is powered on, in range, and available for pairing. You should see the name of your device in the **Available Devices** list if it is ready to pair.
2. Select your device from the list of **Available Devices**. The first time you connect a device, you will be prompted with a passcode to confirm on both Engine OS and Bluetooth devices.

Alternatively, for audio input devices such as smartphones or tablets, navigate to the Bluetooth Settings screen on your device. Then, locate the Engine OS device you would like to pair to and select it.

3. Once successfully linked, your device will appear in the **Linked Devices** list.

Engine OS will automatically determine whether your device is used as an input or output. If your device supports both, a dialog will display to ask you to select one type. You can change this at any time using the **three-dots icon**.

To view device settings

, tap the **three-dots icon** next to the device name.

The **Auto Connect** setting determines how your devices reconnect. When this setting is **On**, a device you have previously paired with your PRIME hardware will automatically reconnect when Bluetooth is enabled and the device is in range. When set to **Off**, you will need to manually reconnect each time.

The **Status** field displays the current connection status.

The **Connection** field allows you to manage your device connection. Tap **Disconnect** to unlink from a connected device. Tap **Forget** to remove a device from the **Linked Devices** list.

Tap **Close** or anywhere outside the window to close the Bluetooth device settings window.

When paired to an audio device, use the **Assign Input To** field to select where the Bluetooth audio will be streamed to: **None**, **Layer A**, or **Layer B**.

When a **Layer** is selected as the Bluetooth audio assignment, you will be able to view Bluetooth track information and play, pause, and skip tracks from your device in Performance View when viewing the selected Layer.

Note: Certain applications may not support track information and performance controls when used with Engine OS devices.

Use the **Bluetooth Device Volume** slider to adjust the Bluetooth device audio input level.

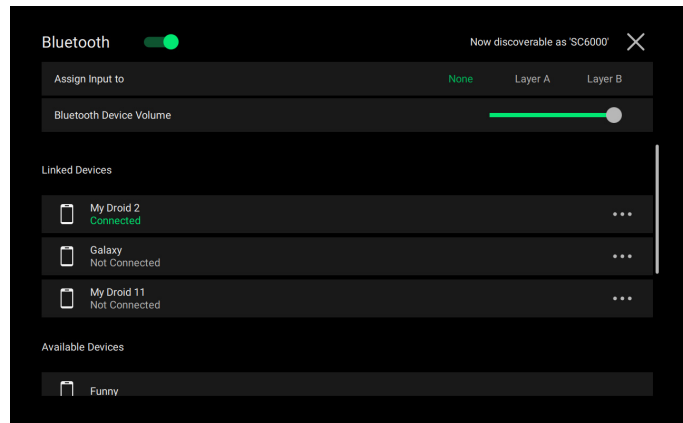

Engine Lighting

The Engine Lighting menu allows you to control connected lighting devices such as DMX fixtures and Smart Lights using SoundSwitch to seamlessly sync your music and lights.

To enable **Engine Lighting**, make sure the **Engine Lighting** option under **Services** in the hardware **Settings** menu is set to **On**. Once Engine Lighting is enabled, you can tap the **gear icon** in the Settings menu to open the lighting control page. You can also access this page after enabling it by double-pressing the **View** button.

The first time you use Engine Lighting, you can select a **Basic** or **Pro** layout for performing (see right):

Basic: A simple interface for controlling Smart Lights, Control Color, Blackout and Strobe Lighting FX.

Pro: Full control of all lighting effects for both DMX and Smart Lights, Control Movements, Strobe and more.

You will also be prompted if you want to connect Philips Hue or Nanoleaf Smart Lights when you first use Engine Lighting. This can also be configured later through the Engine Lighting **Preferences** menu.

Visit [soundswitch.com](https://www.soundswitch.com) for more information on using SoundSwitch lighting controls with your SC6000 or SC6000M PRIME.

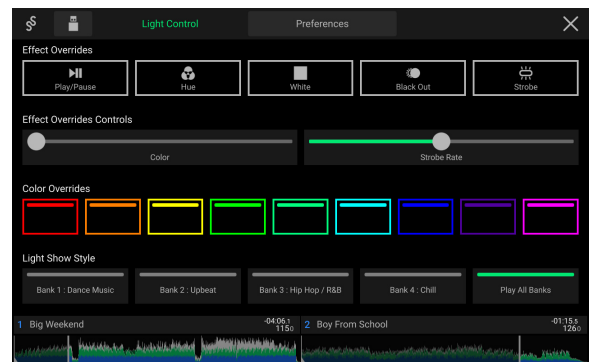
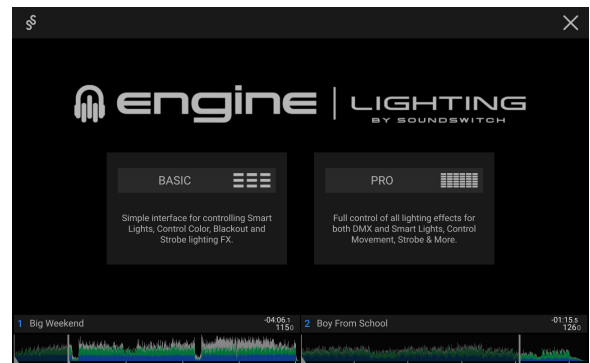

Basic View

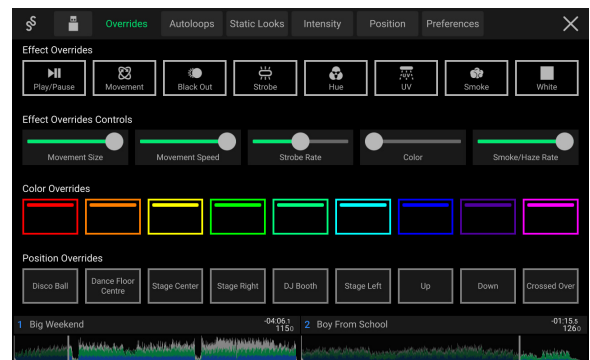

Pro View

Preferences

Tap the **Preferences** tab at the top of the touchscreen to open the Engine Lighting preferences.

General

- **Engine Lighting Status:** This setting displays the current connection status to Engine Lighting devices. When **Running** is shown, Engine Lighting is active. Tap **Stop** to deactivate Engine Lighting. Tap **Start** to reactivate.
- **Connection Status:** These indicators will show whether Engine Lighting is receiving signal from up to four connected players.
- **Sync Offset:** Use this slider to apply a time offset for syncing your connected lights, from **-1** to **0** to **+1** seconds.
- **Show Advanced Controls:** Enable this option to toggle between the **Basic** and **Pro** controls.
- **Randomize Autoloops:** This setting determines whether autoloops are randomized or play in order.
- **Override Scripted Tracks:** This setting determines whether a scripted track that is paired with an audio file is used (**Off**) or whether you can override it using the onboard controls (**On**). This setting takes effect after loading the next track.
- **Loop Auto Strobe:** This setting allows you to automatically generate strobe effects when a Loop Roll is engaged, or when Auto Loop is set to smaller than 1 Beat.
- **Broadcast Art-Net:** This setting allows you to enable or disable sending Art-Net protocol to control DMX interfaces over a network connection.
- **Strobes:** This setting determines whether strobe effects are enabled or disabled.
- **Philips Hue:** Enable this option to connect to available Philips Hue Smart devices.
- **Nanoleaf:** Enable this option to connect to available Nanoleaf devices.
- **Player Mode:** This setting allows you to set whether you are using **2 Player** or **4 Player** operation.
- **Repeat Autoloops Mode:** This setting determines whether autoloops are continuously repeated (**Infinite**) or repeated for the **Track Duration** only.
- **Active Faders:** This setting allows you to enable or disable Engine Lighting control on up to four channels at a time. Tap the **CH1-CH4** names to activate each channel.
- **Version:** Displays the current Engine Lighting version.

DMX Interfaces

Use this menu to view connected DMX interfaces and their Universe Assignments.

Philips Hue

Use this menu to set up Philips Hue devices.

Nanoleaf

Use this screen to set up Nanoleaf devices.

Appendix

SATA Drive Installation

To create internal storage space on your PRIME hardware, you can purchase a **SATA** (Serial ATA) drive and install it yourself, but read this chapter first.

Your PRIME can support nearly any standard 2.5" SATA drive on the market—either a solid-state drive (SSD) or hard-disk drive (HDD). Make sure it uses a **2.5"** (63.5 mm) form factor and uses (or can use) the **exFAT** or **FAT32** file systems.

Note: Alternatively, you could install an **mSATA** (mini-SATA) drive, but make sure you also purchase an adapter that enables it to fit into a typical 2.5" SATA interface.

1. Make sure your PRIME hardware is powered **off**.
2. Locate the **SATA drive panel** in the center of the bottom panel of your PRIME hardware. Use a Phillips-head screwdriver to remove the screws (don't lose them!), and remove the SATA drive panel.
3. Gently pull the **SATA connector and cable** out from inside your PRIME hardware. Be careful not to disturb anything inside—handle just the SATA connector and cable.
4. Connect your **SATA drive** to the **SATA connector**. Make sure the connection is secure.
5. Use four **3x5 mm mounting screws** (included with PRIME hardware or with your SATA drive) to secure the SATA drive to the SATA drive panel. Do not overtighten the screws, but make sure the drive is secure and does not shake.
6. Place the SATA drive panel back onto the bottom panel of your PRIME hardware, and use the original screws to secure it in place.

You can now access this drive while using your PRIME hardware!

Touch FX

LFO Echo	Parameter		Value Range
This effect adds echoes of the original signal, with a filter cutoff frequency varied at a regular rate.	X-Axis	Beats	8, 4, 2, 1, 3/4, 1/2, 1/4, 1/8
	Y-Axis	Resonance	0–100
		Feedback	0–100

Filter Roll	Parameter		Value Range
This effect samples the current audio signal and repeats it at a regular rate based on the current time division, with an additional filter.	X-Axis	Beats	2, 1, 1/2, 1/4, 1/8, 1/16, 1/32
	Y-Axis	Filter	Lo–Hi
		Resonance	0–100

Filter Echo	Parameter		Value Range
This effect adds echoes of the original signal with an additional filter.	X-Axis	Beats	1, 3/4, 1/2, 1/4, 1/8, 1/16
	Y-Axis	Filter	Lo–Hi
		Amount	0–100

Filter Dub Echo	Parameter		Value Range
This effect adds spring reverb-like echoes of the original signal with an additional filter for dub style effects.	X-Axis	Beats	1, 1/2, 1/4, 1/8
	Y-Axis	Filter	Lo–Hi
		Resonance	0–100
		Amount	0–100

Filter Gate	Parameter		Value Range
This effect applies filtered level reduction to the original signal at the set rate.	X-Axis	Beats	1, 1/2, 1/4, 1/8, 1/16
	Y-Axis	Filter	Lo–Hi
		Resonance	0–100

Noise Gate	Parameter		Value Range
This effect applies filtered level reduction and noise to the original signal at the set rate.	X-Axis	Beats	1, 1/2, 1/4, 1/8, 1/16
	Y-Axis	Filter	Lo–Hi
		Reverb	0–100
		Noise Volume	-20 – 15 dB

Filter Reverb	Parameter		Value Range
This effect adds filtered reverberation to the original signal.	X-Axis	Amount	0–100
	Y-Axis	Filter	Lo–Hi
		Room Size	0–100

Flanger	Parameter		Value Range
This effect adds a slightly delayed copy of the original signal to create a comb-filter effect (often referred to as resembling a jet plane engine).	X-Axis	Speed	16, 8, 4, 2, 1, 1/2, 1/4, 1/8
	Y-Axis	Resonance	0–100

LFO Filter	Parameter		Value Range
This effect varies the cutoff frequency at a regular rate.	X-Axis	Beats	8, 4, 2, 1, 3/4, 1/2, 1/4, 1/8
	Y-Axis	Resonance	0–100

Filter	Parameter		Value Range
This effect adds a resonant filter to the original signal.	X-Axis	Resonance	0–100
	Y-Axis	Cutoff	Lo–Hi

Technical Specifications

Analog Output	2.0 Vrms (0 dBFS, 1 kHz)	
Signal-to-Noise Ratio	116 dB	
Distortion (THD+N)	< 0.0015%	
Frequency Range	22–22,000 Hz	
Digital Output	Sampling Rate	96 kHz
	Bit Depth	24-bit
Playable Media	Type	SD, SDHC, SDXC card USB mass-storage devices (flash memory, 2.5" internal SATA, external HDD enclosures)
	File Systems	exFAT (recommended) FAT32 HFS+ (SC6000/SC6000M PRIME only)
	File Formats	AAC/M4A AIF/AIFF (44.1–192 kHz, 16–32-bit) ALAC FLAC MP3 (32–320 kbps) MP4 Ogg Vorbis WAV (44.1–192 kHz, 16–32-bit)
Platters	8.5" / 216 mm (diameter) Metal construction. SC6000/SC5000 with display and capacitive touch	
Displays	Main (SC6000/SC6000M PRIME)	10.1" / 256 mm (diagonal) Full-color LED-backlit display with touch interface
	Main (SC5000/SC5000M PRIME)	7.0" / 178 mm (diagonal) Full-color LED-backlit display with touch interface
	Platter (SC6000/SC5000 PRIME)	2.2" / 56 mm (diameter) Full-color LED-backlit display
Connections	<ul style="list-style-type: none"> (2) RCA output pairs (2) coaxial digital outputs (1) 1/8" (3.5 mm) mini-TS input (remote start) (3) USB Type-A ports (for USB drives) (Rear-panel ports supply 900 mA for USB 3.0 devices, 500 mA for USB 2.0 devices. Front-panel port supplies 500 mA for USB 2.0 devices only.) (1) USB Type-B port (for computer connection) (1) SD card slot (1) Ethernet link port (1) IEC power inlet with locking connector 	

Wi-Fi	Frequency: 2.4 GHz / 5 GHz Standard: 802.11a/b/g/n/ac Power: +17 dBm
Bluetooth Version	5.0
Power	Connection: IEC Input Voltage: 110–240 VAC, 50/60 Hz Consumption: 75 W
Dimensions (width x depth x height)	SC6000 PRIME / SC6000M PRIME: 12.6" x 18.2" x 6.0" / 32.0 x 46.2 x 15.2 cm SC5000 PRIME / SC5000M PRIME: 12.6" x 16.5" x 5.3" / 32.0 x 41.9 x 13.5 cm
Weight	SC6000 PRIME: 12.67 lb. / 5.75 kg SC6000M PRIME: 15.62 lb. / 7.08 kg SC5000 PRIME: 8.79 lb. 3.99 kg SC5000M PRIME: 13.9 lb. / 6.31 kg

Specifications are subject to change without notice.

Trademarks & Licenses

Denon is a trademark of D&M Holdings Inc., registered in the U.S. and other countries. Denon DJ products are produced by inMusic Brands, Inc., Cumberland, RI 02864, USA.

Kensington and the K & Lock logo are registered trademarks of ACCO Brands.

macOS is a trademark of Apple Inc., registered in the U.S. and other countries.

SD, SDHC, and SDXC are registered trademarks of SD-3C, LLC.

The *Bluetooth* word mark and logos are owned by the Bluetooth SIG, Inc., and any use of such marks by Denon DJ is under license.

Windows is a registered trademark of Microsoft Corporation in the United States and other countries.

All other product names, company names, trademarks, or trade names are those of their respective owners.

The following technologies are used in Engine OS products:

ELASTIQUE efficient V3 by zplane.development

TONART V3 by zplane.development

This product uses other software and technology under license. Please visit enginedj.com/product-legal for a complete list.

denondj.com

enginedj.com