

**ION®**

**TAILGATER CLASSIC**

**User Guide**

**English**

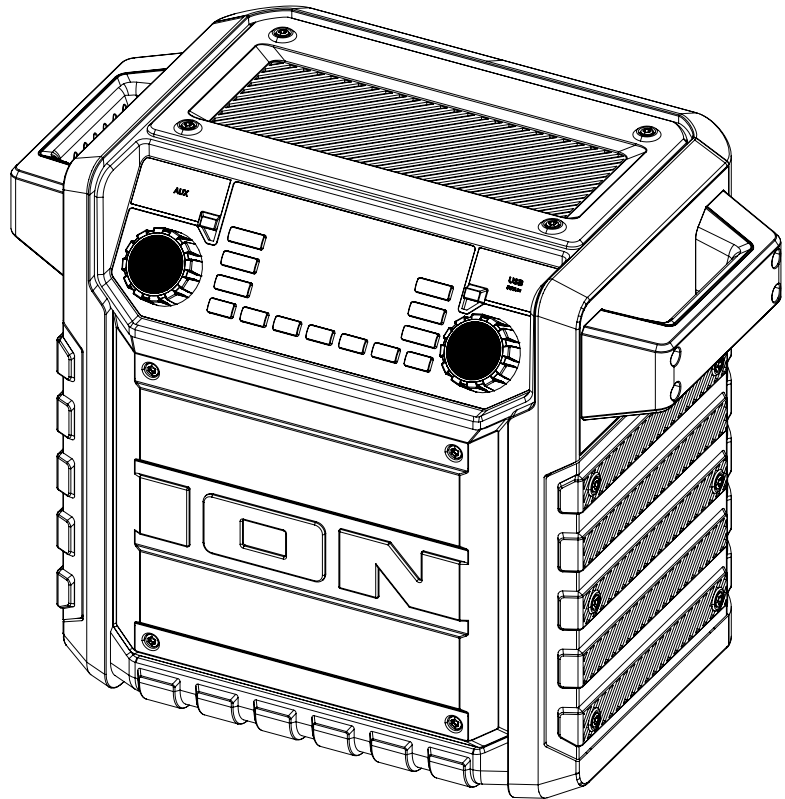

Tap or click  
for technical  
support.

[ionaudio.com/support](http://ionaudio.com/support)

# TABLE OF CONTENTS

<b>INTRODUCTION .....</b>	<b>3</b>
Box Contents .....	3
Support .....	3
<b>SETUP .....</b>	<b>4</b>
Charging and Battery Information .....	4
Outdoor Use and Care .....	5
<b>FEATURES .....</b>	<b>6</b>
Front Panel .....	6
Rear Panel .....	8
<b>OPERATION .....</b>	<b>9</b>
Pairing a Bluetooth® Device .....	9
Linking Two Speakers .....	10
Using the Radio .....	12
Using the USB Charge Port .....	13
App Control .....	14
<b>TROUBLESHOOTING .....</b>	<b>15</b>
<b>APPENDIX .....</b>	<b>16</b>
Technical Specifications .....	16
Trademarks & Licenses .....	17

# INTRODUCTION

Thank you for purchasing the Tailgater Classic speaker. At ION, your entertainment is as important to us as it is to you. That's why we design our products with one thing in mind—to make your life more fun and more convenient.

**Note:** Before you first use the product, please fully charge the batteries. Your unit was purposely shipped with a reduced battery charge to ensure safe transit. For optimal charging, power off the speaker while charging.

Use the included USB-A to USB-C® cable to connect the unit to a 5V, 2A power adapter (not included) connected to a power outlet and let it charge for up to 4 hours (depending on the specifications of your adapter). This helps ensure the longest life for your battery.

## Box Contents

Tailgater Classic

USB-A to USB-C® Charging Cable (3.28 ft. / 1 m)

Quickstart Guide

## Support

For the latest information about this product (documentation, technical specifications, system requirements, compatibility information, etc.) and product registration, visit [ionaudio.com](https://ionaudio.com).

For additional product support, visit [ionaudio.com/support](https://ionaudio.com/support).

# SETUP

## Charging and Battery Information

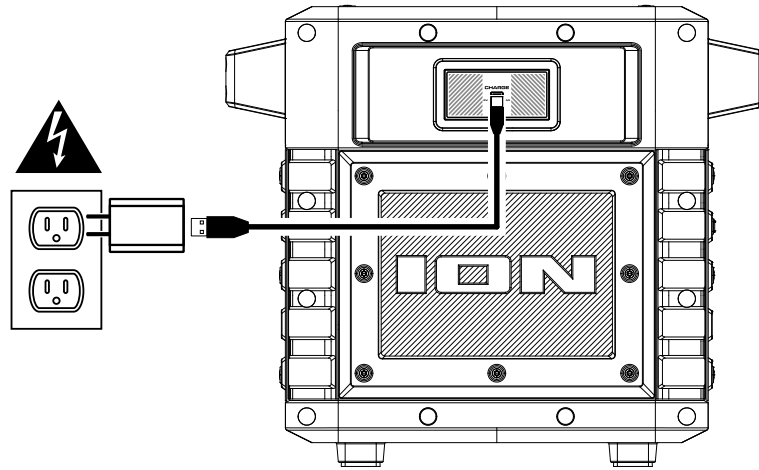

For the quickest charging time, power off Tailgater Classic and use the included USB-A to USB-C® charging cable to connect the USB-C® charging port on the rear panel of the speaker to a USB power adapter (DC 5V 2A, not included) connected to a power outlet, or your computer (powered on). A full charge can take up to 4 hours, depending on the specifications of your 5V, 2A adapter.

The **lightning bolt** icon on the display will light up when Tailgater Classic is connected to a power source and charging. The **battery icon** will fill to display the battery life percentage. When charging is complete, the lightning bolt icon will disappear, and the battery icon will be completely filled.

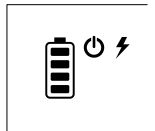

Tailgater Classic will automatically enter a standby mode if no audio is played after 15 minutes while the lights are on and it is not connected to power. Press any button to wake the unit.

Rechargeable lead-acid batteries are the same type used in automobiles. As with your car battery, how you use this battery has a significant impact on its lifespan. With proper use and treatment, a lead-acid battery can last for years. Here are some recommendations for getting the longest life from the internal battery.

- General Usage** Fully charge the battery before using it.  
Charge the battery completely after each use.
- Storage** For best product longevity, do not store at exceedingly hot (greater than 90°F/32°C) or exceedingly cold (less than 32°F/0°C) temperatures.  
It is acceptable to leave your sound system plugged in. This will not overcharge the battery.  
If you leave the battery level low and do not charge it for 3 months, it may permanently lose capacity.
- Repair** If the battery fails to charge, contact ION Audio at [ionaudio.com](http://ionaudio.com).
- Disposal** Bring the unit to a recycling center or dispose of in accordance with local ordinances.

## Outdoor Use and Care

Though Tailgater Classic is water-resistant and able to tolerate splashing water, please review the tips below to get the best performance from your Tailgater Classic:

- Bring Tailgater Classic indoors during extreme weather.
- Please do not place Tailgater Classic in standing water.
- Please do not connect the power adapter to a Tailgater Classic in a wet environment. Make sure the power input, power adapter, and power outlet are all completely dry before making any connections.
- **WARNING:** Keep any non-water-resistant devices (phones, music players, etc.) in a dry place where they will not be affected by water and cause a risk of electric shock.

# FEATURES

## Front Panel

Click a control below to jump to that section.

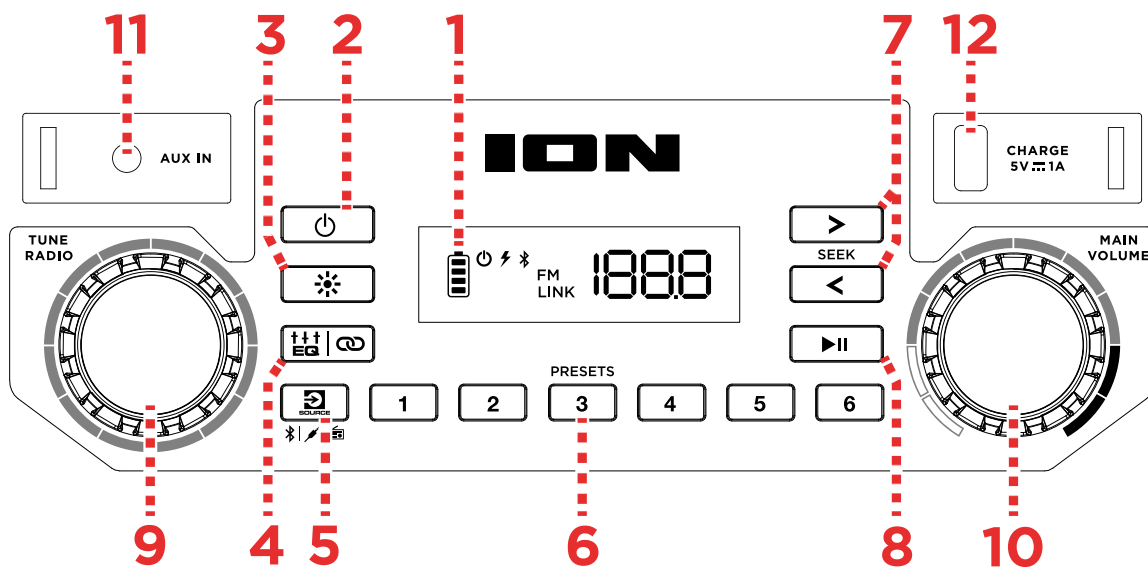

### 1. Display

This screen shows information relevant to the current operation on Tailgater Classic.

- **Charging Indicator:** When the power cable is connected, movement of the top battery segment shows the battery is charging.



When fully charged, all battery segments will be lit without blinking. When the power cable is disconnected, the battery segment shows the level of the battery.

- **Power Indicator:** The power indicator will illuminate when Tailgater Classic is powered on.
- **Lightning Bolt Icon:** The lightning bolt icon will illuminate when the IEC power cable is connected to wall power.
- **Bluetooth Icon:** The Bluetooth icon will not be lit when Tailgater Classic is first powered on (unless it was previously paired with a device). The Bluetooth icon will be lit solid when a device is paired to Tailgater Classic.
- **FM:** This icon will illuminate when using FM Radio mode.
- **LINK:** This icon will illuminate when Stereo-Linked to another Tailgater Classic.
- **Radio:** These numbers indicate the current radio station in FM Radio mode.

**Note:** The Display comes with a plastic protector on it. Remove this for optimal viewing.

## 2. Power Button

Press and hold this button to turn Tailgater Classic on and off.  
Double-press this button to turn Voice Prompts on or off.

## 3. Lights Button

Press this button to cycle through the three brightness levels for the utility light, or to turn the lights off.

**Note:** If the lights are on and Tailgater Classic is not connected to a power source, the speaker will enter a standby mode after 15 minutes if no audio is playing. To wake the unit, press any button. To continue to use the lights without playing audio, make sure Tailgater Classic is connected to a power source.

## 4. EQ / Stereo-Link™ Button

Press this button to cycle through the Low, Mid, and Hi EQ bands, as shown on the **Display**. Then, use the **MAIN VOLUME knob** to adjust the EQ frequency settings from -6 to +6.

Press and hold this button to start stereo-linking to another Tailgater Classic. See [Operation > Linking Two Speakers](#) for more details.

## 5. Source Button

Press this button to cycle between Bluetooth, Aux, and Radio modes. The current mode will be shown on the **Display**.

## 6. Preset Buttons

In radio mode, press and hold these buttons to save the current station as a preset. Press and release these buttons to recall the saved station.

## 7. Next / Previous Buttons

In Bluetooth and USB modes, press the **Next** button to skip to the following track. Press the **Previous** button to go to the beginning of the current, and press it again within one second to skip to the previous track.

In radio mode, press and hold these buttons to seek the previous or next strong station.

## 8. Play/Pause Button

Press this button to start and stop Bluetooth or USB audio.

## 9. Tune Radio Knob

Turn this knob left or right to move to the previous or next radio station.

## 10. Main Volume Knob

Turn this knob to adjust the speaker's overall volume.

## 11. Aux In

This stereo 1/8" (3.5 mm) input can be used to connect a CD player, MP3 player, or other audio source.

## 12. USB-A Charge Port (5V, 1A)

You can use this port for charging the USB device, such as a tablet or smartphone. USB charging only functions when the unit's power is turned on.

**Note:** To charge smartphones and tablets faster, put the device's screen to sleep.

## Rear Panel

**Note:** Pull the tab on the protective rubber panel to release it and access the rear panel port.

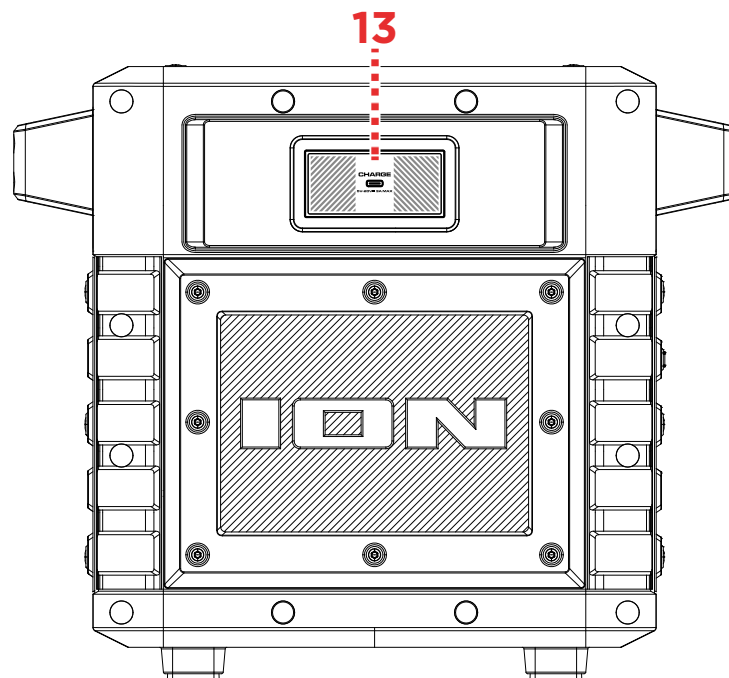

## 13. USB-C® Charge Port

Connect the included USB-A to USB-C® charging cable from this charging port to a USB power adapter (DC 5V 2A, not included) connected to a power outlet, or to your powered-on computer.

# OPERATION

## Pairing a Bluetooth® Device

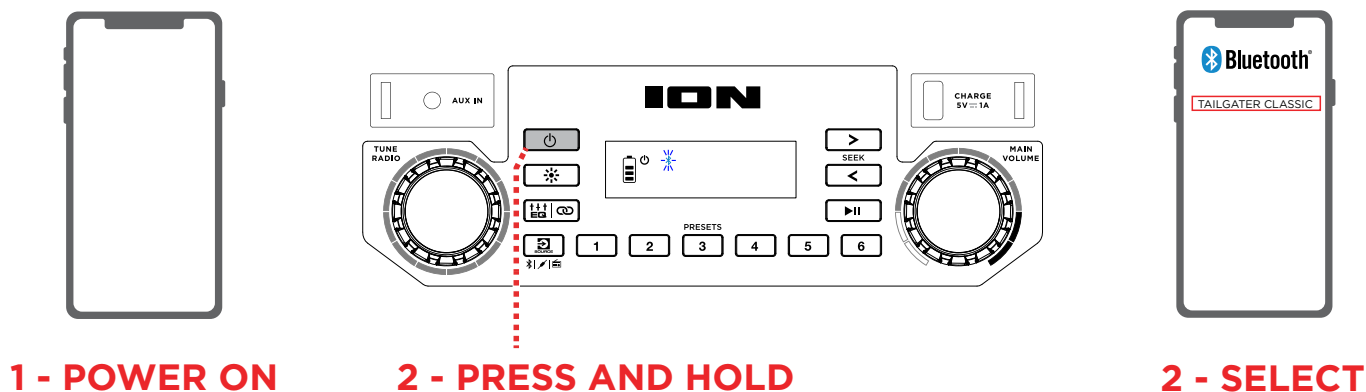

1. Turn on your Bluetooth device.
2. Turn on Tailgater Classic by holding down the **Power** button for 2 seconds.

When the unit is first turned on, it will automatically enter Bluetooth pairing mode. If necessary, press the **Source** button to select Bluetooth mode. The Bluetooth icon on the display will flash to indicate the speaker is ready to pair and you will hear “Bluetooth Pairing” if voice prompts are enabled.

3. Navigate to your device’s Bluetooth setup screen, find **Tailgater Classic**, and connect. The **Bluetooth icon** will appear in the display, and if voice prompts are enabled, you will hear “Bluetooth Connected”.

**Note:** If your Bluetooth device prompts for a pairing code, enter “0000”.

To disconnect a paired device, do any of the following:

- Turn off Bluetooth from your device’s Bluetooth settings. The speaker will enter Bluetooth pairing mode to make it available for another device.
- Double-press the **Source** button.

Once you have disconnected, you will hear “Bluetooth Disconnected” if voice prompts are enabled.

**Tip:** Double-press the **Power** button to turn voice prompts on or off.

## Linking Two Speakers

If you would like to play music from a Bluetooth device, you can first “link” two Tailgater Classic speakers together in order to listen to your music in stereo. One Tailgater Classic will serve as the left speaker and the other will serve as the right speaker.

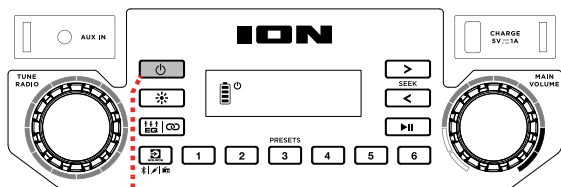

**1 - PRESS AND HOLD BOTH SPEAKERS**

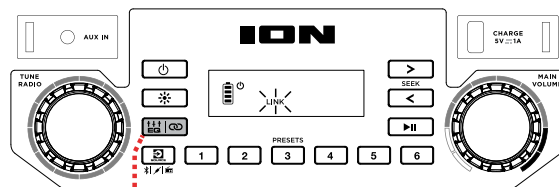

**2 - PRESS AND HOLD BOTH SPEAKERS**

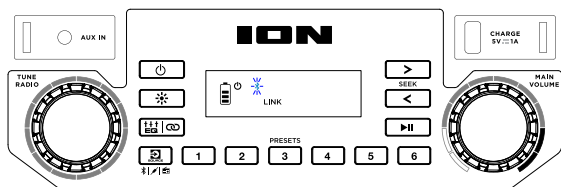

**3 - PAIRING**



**4 - SELECT**

To link two Tailgater Classic speakers together:

1. Power on both speakers by pressing and holding the **Power** button.
2. Press and hold the **EQ / Stereo-Link™** button on both speakers to enter Stereo-Link™ mode. The **LINK** icon on each display will flash.

**Note:** When you begin the Stereo-Link™ process, any connected Bluetooth devices will be automatically disconnected. You can also disconnect your device prior to beginning by double-pressing the **Source** button.

3. The speakers will automatically connect. This process may take up to 30 seconds, and once completed, the **LINK** icon will be solidly lit. This first unit entered into Stereo-Link™ mode will be the primary speaker and play the left channel, and the second speaker will be the right channel.

**Note:** Speakers should be within 50' (15 m) of each other to properly link. The closer the two speakers are, the quicker the link is established.

4. Once the speakers are linked, the primary speaker will automatically enter Bluetooth pairing mode. Navigate to your device's Bluetooth settings screen, find **Tailgater Classic**, and connect. When the connection is successful, you will hear "Bluetooth Connected" from the primary speaker (if voice prompts are enabled). Playback controls are active on both speakers.

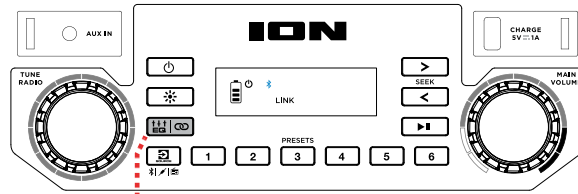

## DOUBLE-PRESS

To disconnect two speakers or cancel linking between the two, double-press the **EQ / Stereo-Link™** button on one Tailgater Classic. You will hear "Bluetooth Disconnected" from the primary speaker to indicate the link has been broken (if voice prompts are enabled.)

**Note:** Press and hold the **Power** button on each speaker while in Stereo-Link™ mode to power off the connected speakers. Tailgater Classic speakers powered off in Stereo-Link™ mode will automatically enter Stereo-Link™ mode the next time they are powered on and begin searching for secondary speakers to connect to.

## Using the Radio

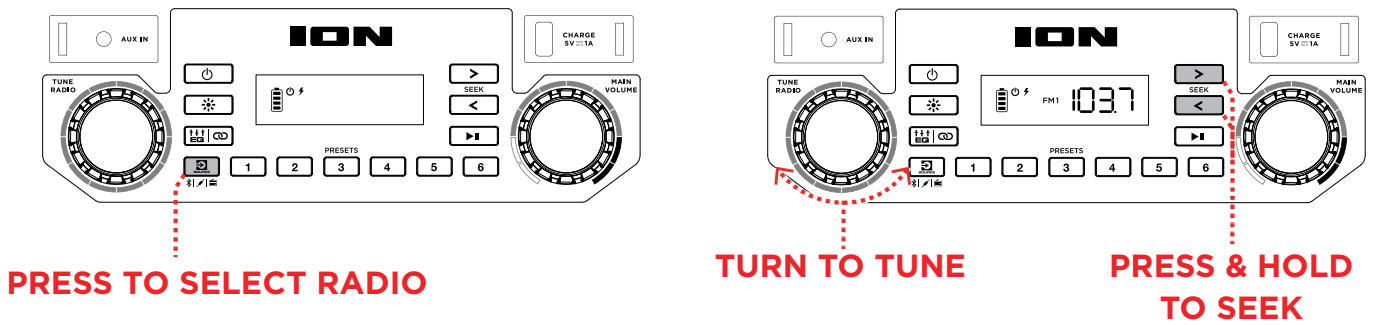

To use the radio, press the **Source** button so that **FM** is selected and shown on the display.

While in radio mode, turn the **Tune Radio** knob left or right to move to the previous or next available radio station. You can also press and hold the **Previous / Next** buttons (< / >) to seek the previous or next strongest station.

To save a radio station as a preset, press and hold a **Presets** button.

To recall a previously saved preset, press and release a **Presets** button.

## Using the USB Charge Port

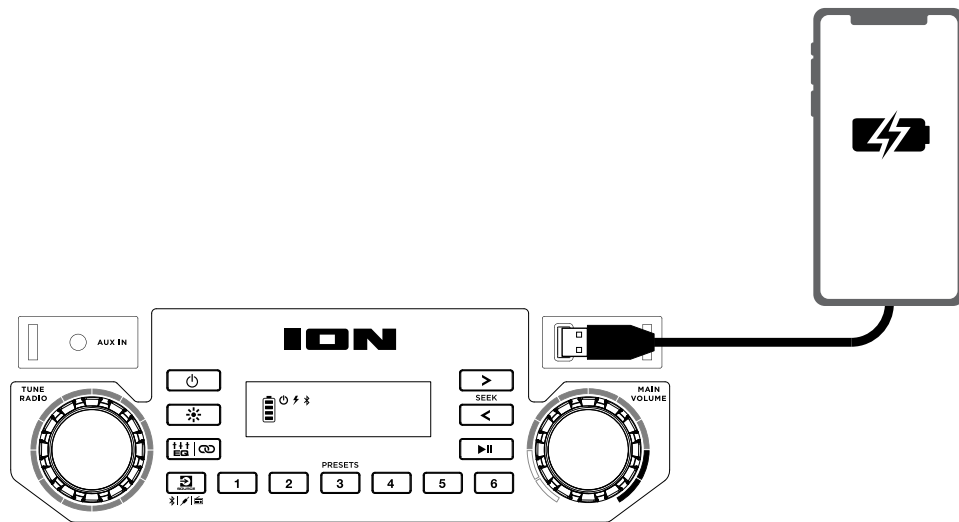

### To use the USB charge port:

1. Connect a USB type-A cable to the **USB Charge Port** on the front panel of your Tailgater Classic speaker (see image).
2. Connect the other end of the cable to the charging input on your smartphone, tablet, or other compatible device.

## App Control

**IMPORTANT:** To ensure the best possible experience with the app, use the most current Android OS or iOS on your device.

Follow these steps to download the free app on your device:

1. Open the Apple App Store or Google Play on your device. Then, search for the **ION Sound Control™** app.
2. Follow the on-screen instructions to download and install the app. Once downloaded, the **ION Sound Control™** app will appear on your device's home screen.
3. Connect your device to Tailgater Classic via Bluetooth. See [Operation > Pairing a Bluetooth® Device](#) to learn how to do this.
4. Open the ION Sound Control™ app. If prompted, allow the app to access your device's Bluetooth and Location Services.
5. Follow the steps on screen to find and connect to your Tailgater Classic. Once connected, you can control various functions of the speaker, such as:
  - **Volume:** Adjust the speaker's volume.
  - **EQ:** Adjust the speaker's equalization.
  - **Voice Prompts:** Enable or disable the voice prompts.
  - **Lights:** Change the brightness of the utility lights.
  - **Battery Life:** Check the speaker's battery life status.
  - **Support:** Visit [ionaudio.com](http://ionaudio.com), contact Technical Support, and view Warranty information and Frequently Asked Questions.

# TROUBLESHOOTING

**If the unit is not charging:** Make sure the power cable is properly connected to the power input and the power outlet.

**If the sound is distorted:** Try lowering the volume control of your sound source.

**I hear a hum when cables are connected:**

- Disconnect cables from the input jacks to see if it's a faulty cable.
- Make sure the signal cables are not placed near power cables.
- Connect all audio equipment power cables to outlets which share a common ground.

**If there is too much bass:** Try adjusting the tone or EQ control on the Tailgater Classic or your sound source to lower the bass level. This will allow you to play the music louder before clipping (distortion) occurs. You can also check to see if the **BOOM** function is enabled, and disable it by pressing the **BOOM** button™.

**If you cannot connect your audio device to Tailgater Classic via Bluetooth:**

- Have your audio device (e.g., smartphone or tablet) and Tailgater Classic as close together as possible while trying to connect. Make sure both the audio device and Tailgater Classic are unobstructed by walls, furniture, etc.
- Press the **Bluetooth** button to disconnect Tailgater Classic from any other audio device and restart the search process. If this does not work right away, power off Tailgater Classic and then power it back on. See [Operation > Pairing a Bluetooth® Device](#) for more information.
- Reset the Bluetooth connection on your audio device by turning Bluetooth off and back on. You can find this under the Bluetooth menu in the Settings for your phone or other audio device.

If this does not work, and you have connected to Tailgater Classic before, find Tailgater Classic in the list of available or previously connected devices in your audio device's Bluetooth menu, tap the "gear" or "i" icon located next to it and then select **Unpair** or **Forget**. Turn Tailgater Classic off and back on and try pairing again once it reappears in your available devices list.

**Note:** If Tailgater Classic has been paired to another audio device recently that is still within range, you may need to repeat this process with that audio device to fully disconnect.

**If you experience audio dropouts while playing music from a Bluetooth device,** this may be happening because your unit is trying to link to another speaker. This can occur if you power off a speaker that was linked to your unit or if you have just turned on your unit and it is in Stereo-Link™ mode. To stop the audio dropouts, exit Stereo-Link™ mode by double-pressing the **EQ / Stereo-Link™** button. Alternatively, you can wait for your unit to link to another speaker if there is one within range.

# APPENDIX

## Technical Specifications

<b>Speakers</b>	<b>Low Frequency:</b> 8.0" (205 mm) woofer <b>High Frequency (front):</b> 2.3" (59 mm) tweeter <b>Full-Range Driver (sides):</b> (2) 3.9" (98 mm)
<b>Frequency Response</b>	45 Hz - 20 kHz
<b>USB</b>	<b>Supported File System:</b> FAT32 <b>Supported File Types:</b> MP3 <b>Maximum File Size:</b> 4 GB
<b>Wireless Technology</b>	<b>Bluetooth®</b> - Classic Audio
<b>Wireless Range *</b>	<b>Bluetooth Range:</b> Up to 100 ft. (30.5 m) <b>Stereo-Link™ Range:</b> Up to 50 ft. (15 m) between speakers
<b>Battery</b>	<b>Capacity:</b> 5Ah/12V, 60Wh <b>Battery Life:</b> 15+ hours ** <b>Charge Time:</b> Up to 4 hours
<b>Power</b>	<b>Cable:</b> IEC (C7) Power Cable <b>Input Voltage:</b> 100-240 V~, 50/60 Hz, 120 W
<b>Dimensions</b> (width x depth x height)	14.19" x 8.13" x 17.87" 368 mm x 207 mm x 454 mm
<b>Weight</b>	14.99 lbs. 6.8 kg

Specifications are subject to change without notice.

\* Bluetooth and wireless reception and range are affected by walls, obstructions, and movement. For optimal performance, place the product so it is unobstructed by walls or furniture and is raised off the ground.

\*\* Battery performance varies with the features being used on the unit and volume at which content is being played. In typical usage for audio playback, exclusive of additional features, the Tailgater Classic battery lasts 15+ hours with speaker volume at 50% and the lights off.

## Trademarks & Licenses

ION Audio is a trademark of inMusic Brands, Inc., registered in the U.S. and other countries.

The *Bluetooth* word mark and logos are owned by the Bluetooth SIG, Inc., and any use of such marks by ION Audio is under license.

App Store is a trademark of Apple Inc., registered in the U.S. and other countries.

Android and Google Play are registered trademarks of Google Inc. All other product names, company names, trademarks, or trade names are those of their respective owners.



[ionaudio.com](http://ionaudio.com)