

General Description

“Oh, my aching back!” and “Dang, I’m outta rack space!” are the battle cries of road warriors everywhere. The MP 2 Mobile Mixer is designed specifically for the *on-the-go* discriminating DJ. The MP 2 is compact in size and refreshingly lightweight. Don’t let its petite appearance fool you. This mixer may be skinny in stature, but it’s fat on features and function. The MP 2 is easy on your back, easy on your wallet, and music to your ears!

The MP 2 is packed with all the necessary features for a great performance and perfect mix. Each Program bus selects any of the four stereo Inputs. Any Input can appear on either side of the Crossfader! You have two selectable phono/line Inputs and

two stereo line Inputs for each of the two Program buses. Each Program bus has its own Bass and Treble EQ.

Identical to other Rane mixers, the crossfader is a long lasting, noise-free 60 mm *Active Crossfader*™.

The MP 2 includes many additional important features. Cue Engage on each bus, Headphone slide fader that pans Cue to Master and a powerful low-noise Headphone Amp with Level control, of course. You also get a balanced Main Mic input with full-range fader control. Outputs include a Tape Out with Pre/Post Mic sum, a balanced Auxiliary Output with Level control for booth monitoring or feeding an additional zone and a balanced house feed.

Features

- High performance VCA Active Crossfader
- Compact & Mobile 1U design
- Loud, high quality headphone amplifier
- Phono/Line switchable inputs
- Two stereo, balanced outputs
- Separate EQ on each bus
- Separate meter on each bus

Applications

- Mobile DJ
- Night Club mixing
- Radio Remote Broadcasting
- Remix Project Studio
- Post Production
- Anywhere rack space is tight, mobility is a must and Rane quality is demanded.



Parameter	Specification	Conditions
Phono Inputs:	2 stereo pairs	RCA jacks, RIAA curve ±2 dB
.....Input Impedance	47k / 220pf	
.....Gain	46 dB	1 kHz
Line Inputs:	2 stereo pairs	RCA jacks
.....Input Impedance	20 kΩ	1 kHz
.....Gain	14 dB	1 kHz
.....Frequency Response	10-27 kHz (+0, -3 dB)	Gain 10 dB, 2 kΩ load
.....Noise, Unity Gain	-82 dBu	20 kHz BW
.....Noise, Max Gain	-80 dBu	20 kHz BW, re +4 dBu
.....THD+N	0.05%	20 kHz BW, 20-20k Hz, +0 dBu
.....Crosstalk	<-70 dB	1 kHz
.....Control feedthrough	<-80 dB	1 kHz
Tone Controls:	Baxandall	Two-band, shelving
Metering:	Dual mono, 4-segment	-24, -12, 0, +12 dBu, peak responding
MIC Input:	Balanced instrumentation	¼" TRS Jack
.....Input Impedance	511 Ω	Each leg to ground, 1 kHz
.....Gain	50 dB	1 kHz
.....Frequency Response	20-20k Hz (+0, -3 dB)	Gain 50 dB
.....Equivalent Input Noise	-111 dBu	150 Ω source, gain 50 dB
.....Common Mode Rejection	>40 dB	150 Ω source, gain 50 dB, 1 kHz
House / Aux. Outputs:	Stereo	Balanced, ¼" TRS jacks
.....Output Impedance	102 Ω	each leg, 1 kHz
.....Gain	6 dB	1 kHz
.....Maximum Output	+26 dBu	1 kHz, 2 kΩ load
Tape output:	Stereo	RCA jacks, unbalanced
.....Output Impedance	300 Ω	each leg, 1 kHz
.....Gain	0 dB	1 kHz
.....Maximum output	+22 dBu	1 kHz, 2 kΩ load
Power Supply:	18 VAC center tapped	750 mA rms max
	Remote RS 1 Supply	See RS 1 Data Sheet
Agency Listing:	Class 2 equipment	National electric code
.....120 volt units	UL / CSA exempt	Exempt class 2
.....230 volt units	CE-EMC	EMC directive 89/336/EEC
	CE-safety exempt	Article 1 of LV directive 73/23/EEC
Power Supply (120 volt):	UL / CSA	File no. E88216 / file no. LR58948
Power Supply (230 volt):	CE-EMC	EMC directive 89/336/EEC
	CE-safety	LV directive 73/23/EEC
Construction:	All Steel	Standard 19" x 1U rack-mount
.....Unit Size	1.75"H x 19"W x 5.3"D	4.4 cm x 48.3 cm x 13.3 cm
.....Unit Weight	4 lb	1.8 kg
.....Shipping Size	4.25" x 20.3" x 13.75"	11 cm x 52 cm x 35 cm
.....Shipping Weight	8 lb	3.6 kg

Note: All specifications are typical unless otherwise stated.

Block Diagram

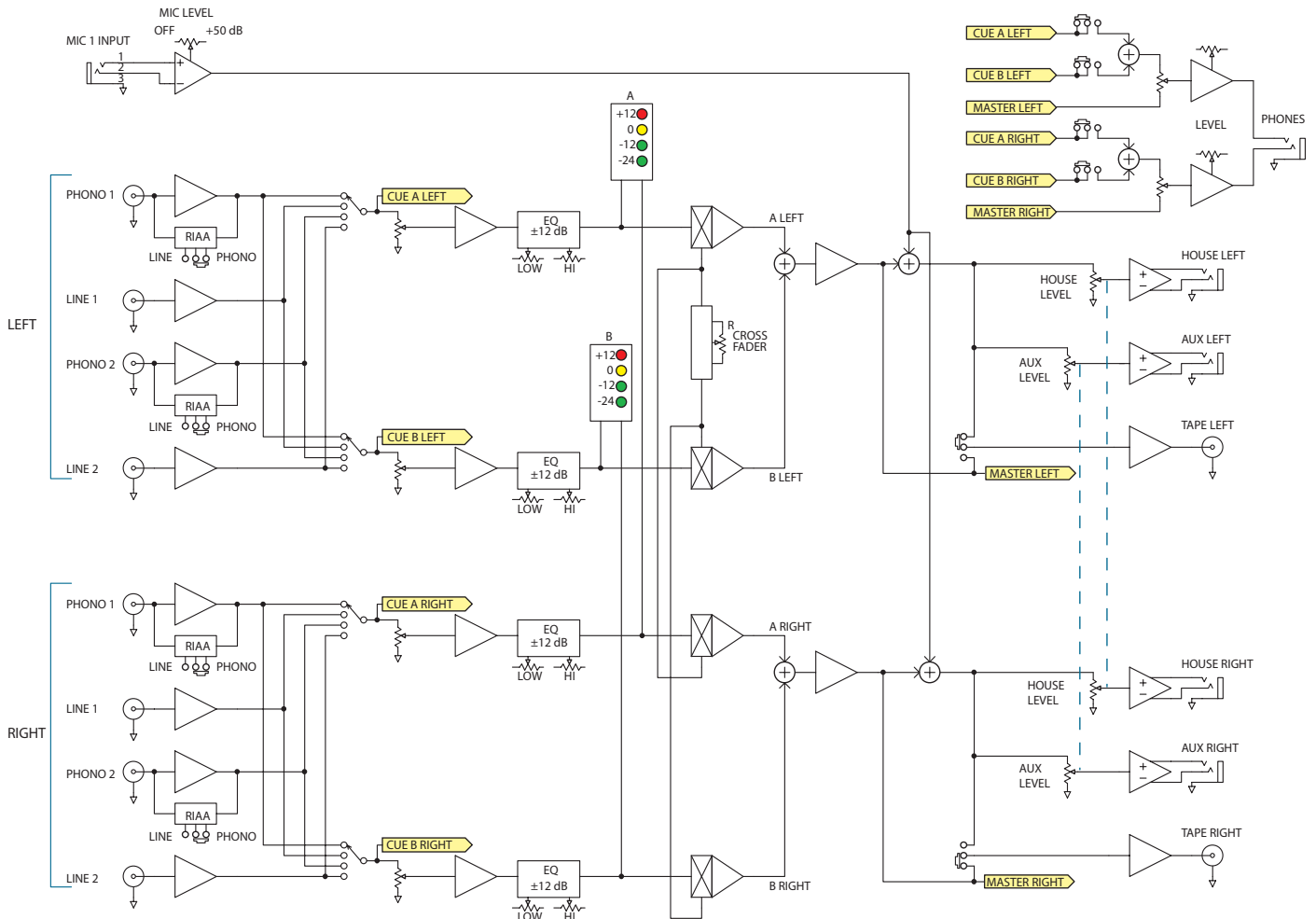

Architectural Specifications

The MP 2 shall be a small, lightweight DJ mixer occupying 1U in a standard 19" rack. The mixer shall include two stereo phono inputs and two stereo line-level inputs. The phono inputs shall include a switch to allow line level operation. The mixer shall have two stereo mixing channels. A 60mm, high performance VCA crossfader shall be provided. Each of the four stereo inputs shall be assignable to the A-side and/or B-side of the crossfader. Dual-mono metering shall indicate the mix level of Program-A and Program-B.

A balanced microphone input with 1/4" TRS jack shall be provided. The gain range shall be continuously adjustable from off to +50 dB.

The MP 2 shall have a stereo, balanced house output and a stereo balanced auxiliary output with independent level control. A stereo unbalanced tape output shall include a switch to select pre- or post-microphone operation. Headphone monitoring shall include independent cue switches for program one and program two, panning between master mix and cue selection and a level control. Output shall be via a 1/4" TRS jack.

The unit shall be powered by an external RS 1 power supply. The power supply shall be UL listed, CSA certified and CE certified. The unit shall be CE certified.

The unit shall be a Rane MP 2 Mixer

Rear View



Example System Diagram

